

# TELESKOPLAR

**Serdar Evren**

**Ege Üniversitesi  
Astronomi ve Uzay Bilimleri Bölümü**

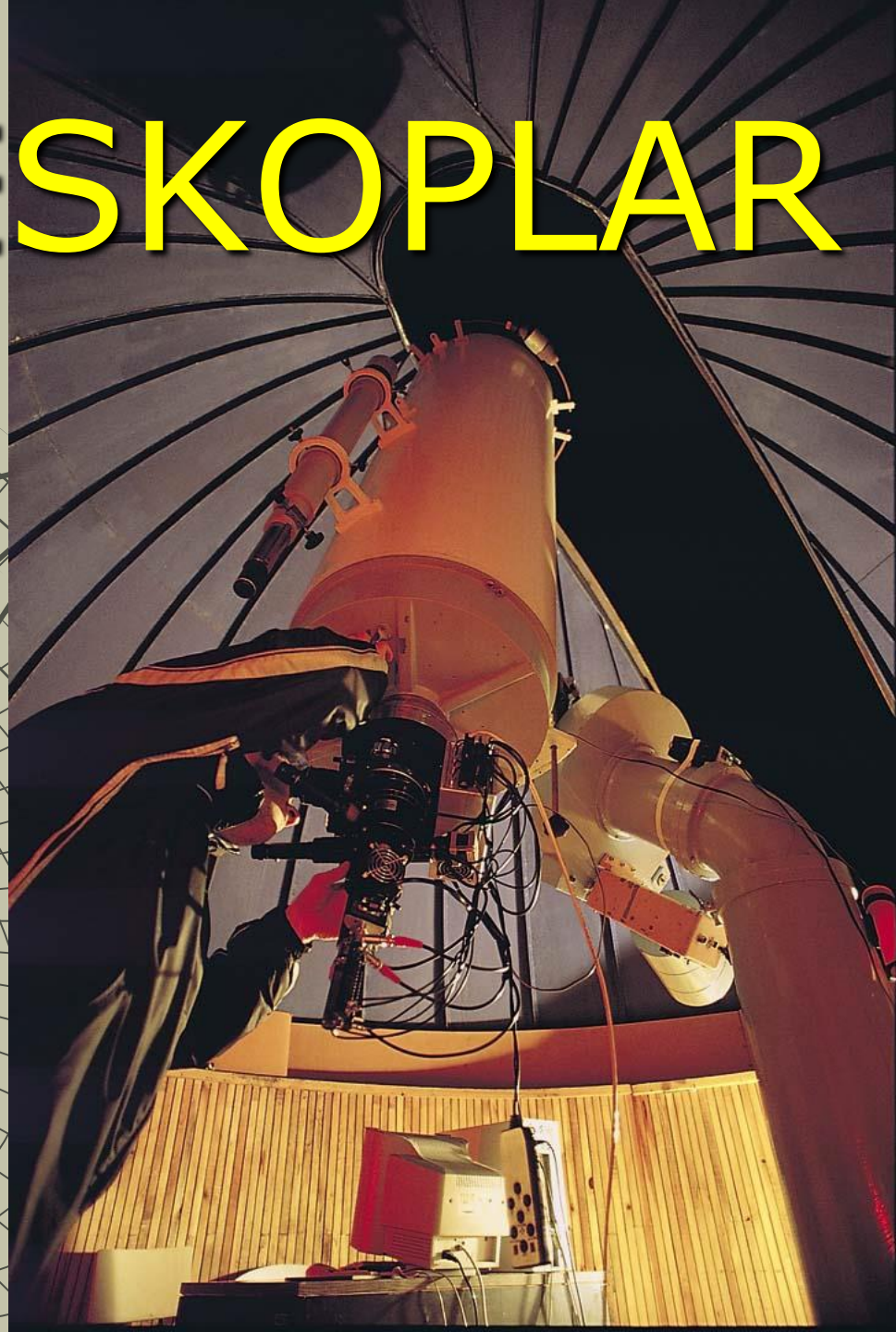

# Teleskop: Elektromanyetik ışığı toplayan en önemli alet

- ◆ Teleskoplar, gök cisimlerinin görünürdeki parlaklıklarını ve açısal boyutlarını artırır.
- ◆ [Galileo Galilei](#), teleskobu 1609'da astronomik amaçlar için kullandı. Kısa zaman sonra, [Johannes Kepler](#) mercek optiğini açıkladı.
- ◆ "Teleskop" sözcüğü genelde [optik teleskoplar](#) için kullanılır. Ancak, elektromanyetik tayfin diğer ışınimleri için de değişik teleskoplar vardır.

# Elektromanyetik Işınım

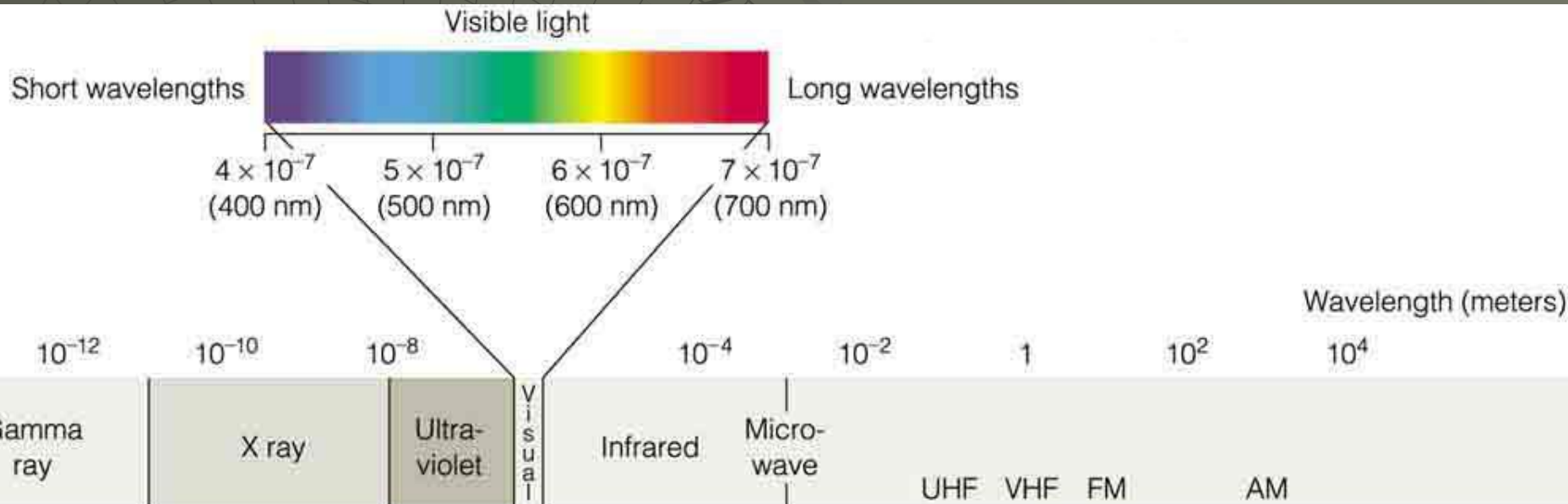



# MERCEKLER





# Mercek

[http://en.wikipedia.org/wiki/Lens\\_%28optics%29](http://en.wikipedia.org/wiki/Lens_%28optics%29)

- ◆ Şekilli bir cam parçasından oluşmuş, ışığı odaklamaya yarayan bir alet.
- ◆ Mercek; eğrilmiş şekilli, iki yüzeyli cam veya optik olarak geçirgen bir maddeden oluşur.
- ◆ Mercek maddesinin kırılma indeksi ve iki yüzeyin eğriliği, her merceğe ayrı bir özellik katar.

Bir mercek, içinden geçen ışığı prizmada olduğu gibi kırar.

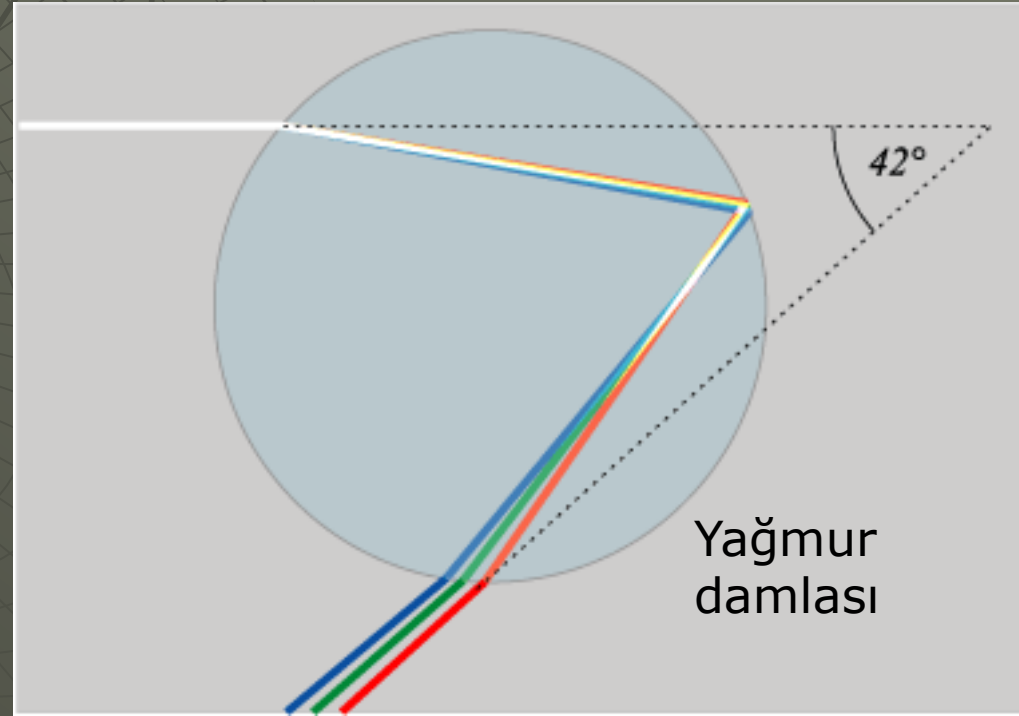
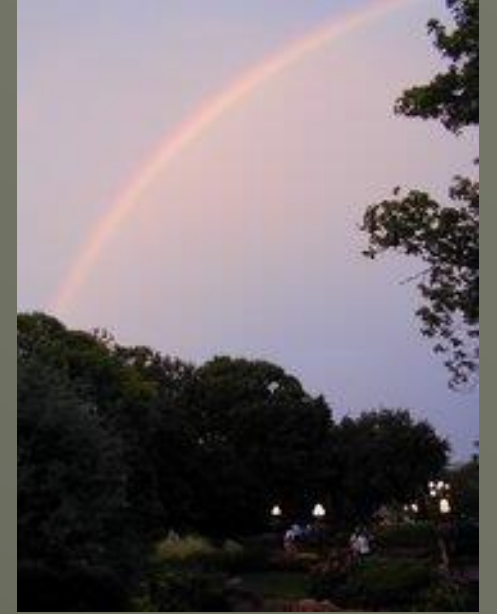
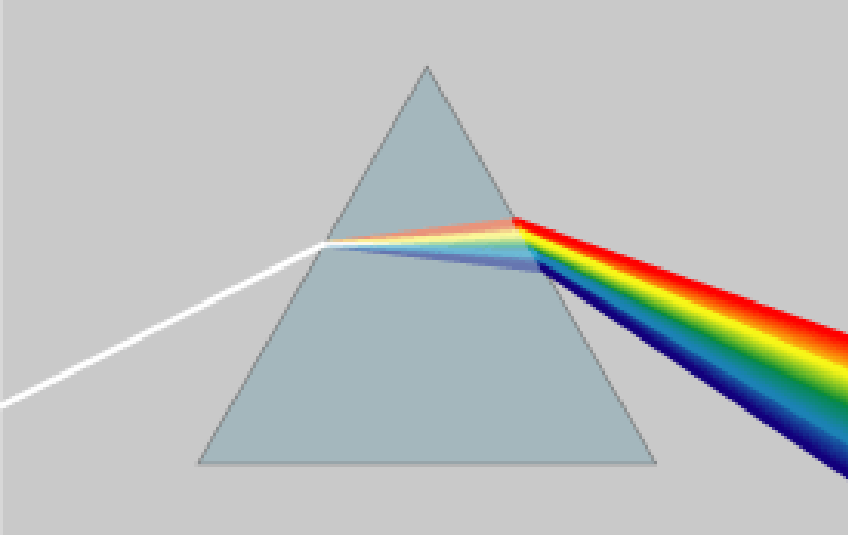

<http://en.wikipedia.org/wiki/Rainbow>

# Renk Uzayı

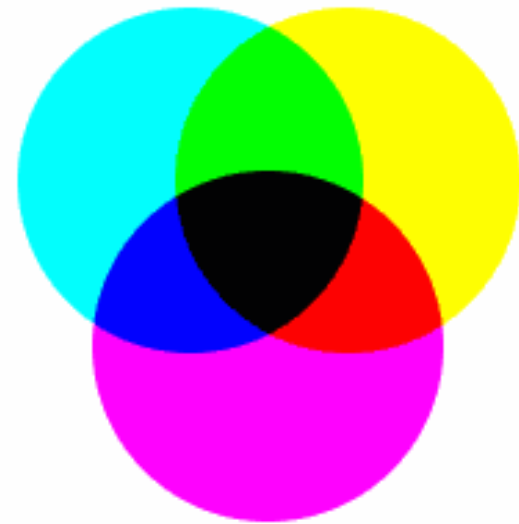
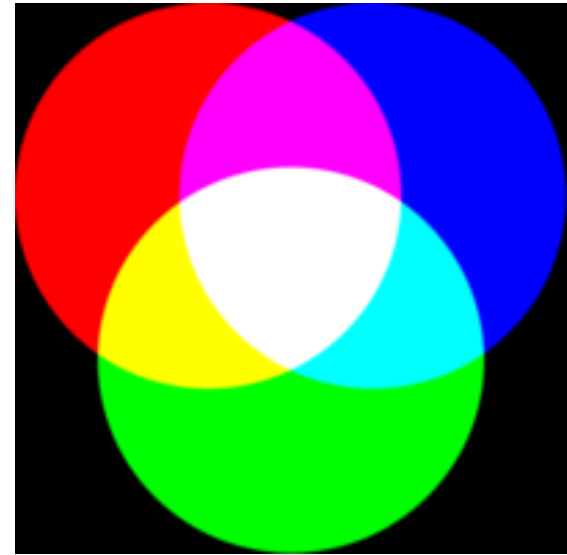

<http://en.wikipedia.org/wiki/Color>



# Yakınsak (İnce Kenarlı, Pozitif) Mercek

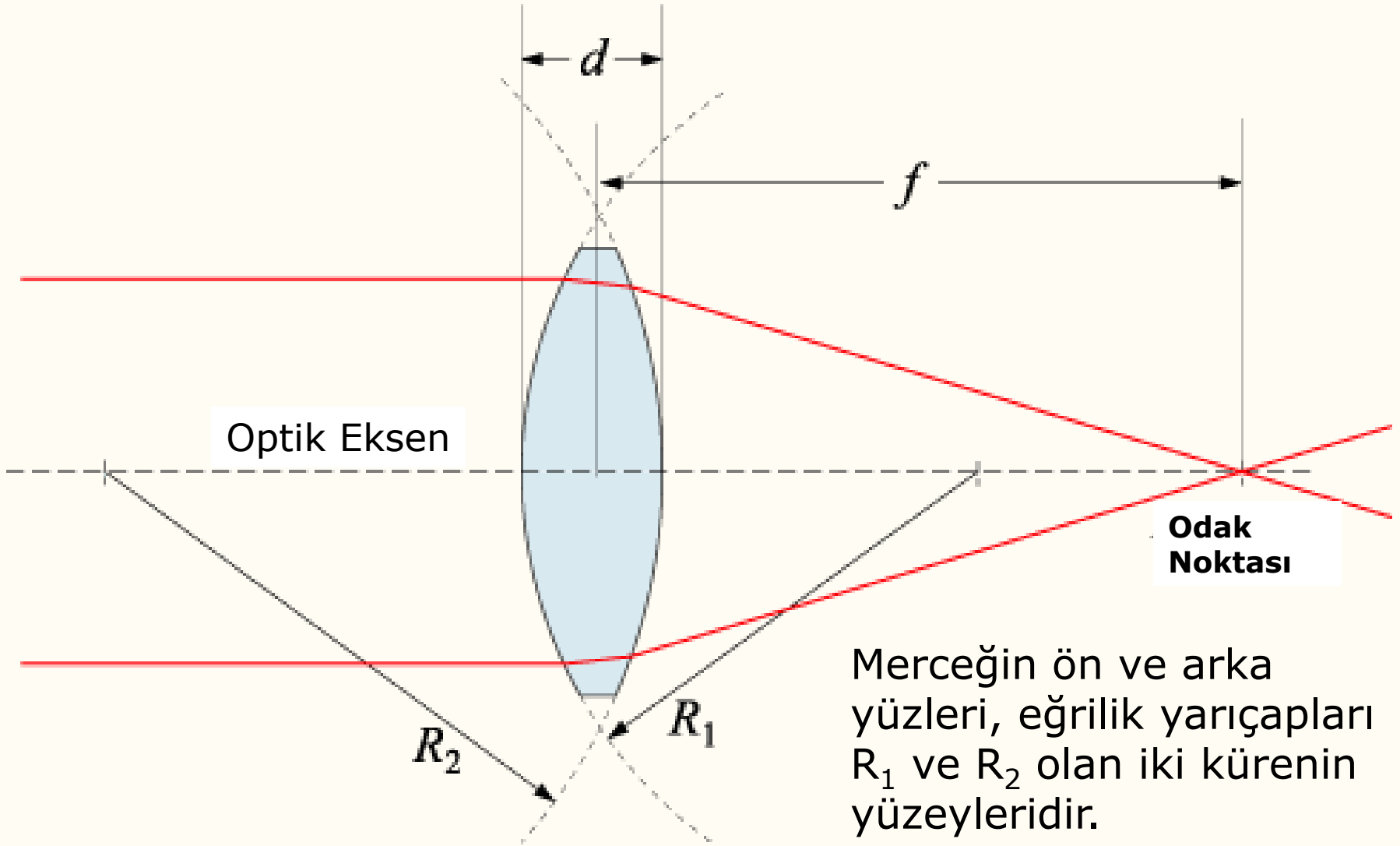

Merceğin ön ve arka yüzleri, eğrilik yarıçapları  $R_1$  ve  $R_2$  olan iki kürenin yüzeyleridir.

Pozitif (yakınsak)mercek

# İnce Kenarlı Mercek

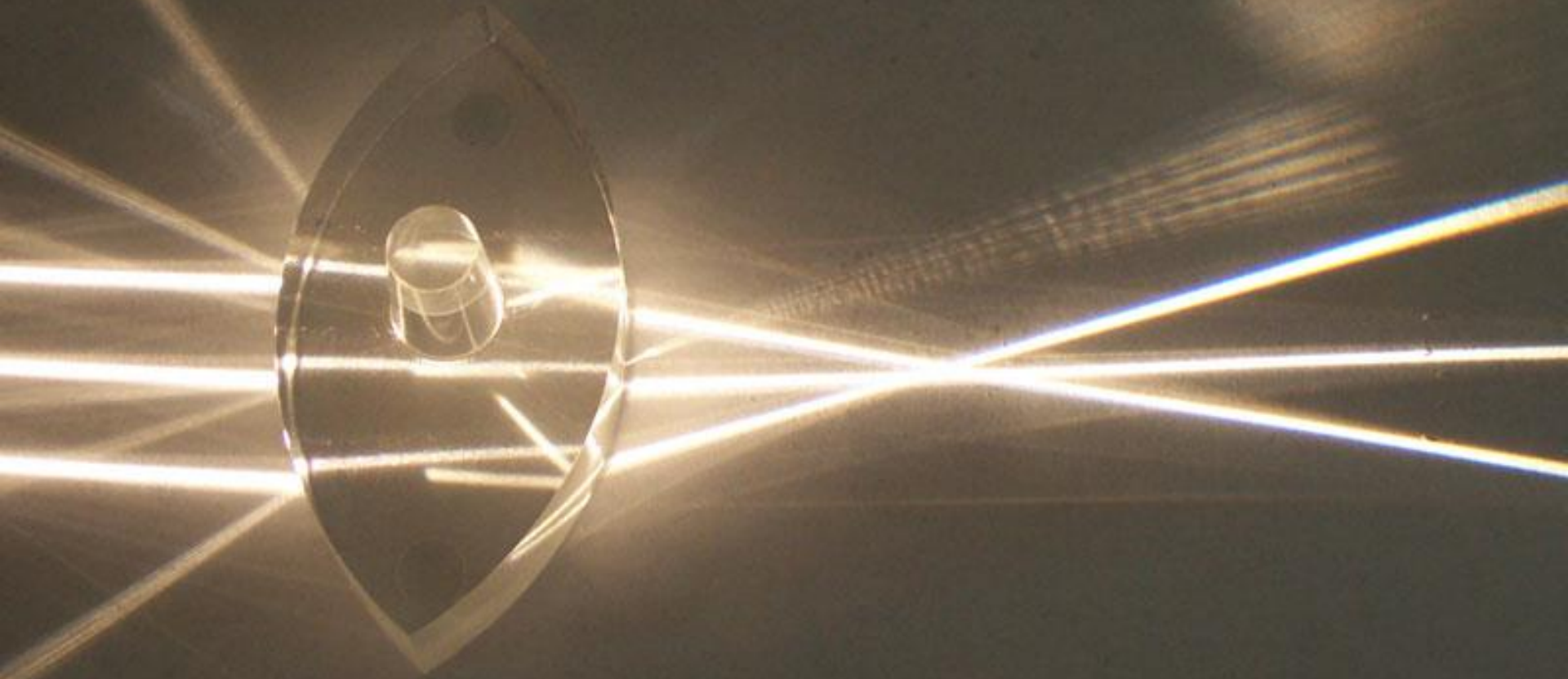

# Eğrilik Yarıçapı

- ◆  $R_1$ 'in işareti merceğin ön yüzünün şeklini verir:
- ◆ Eğer,  $R_1$  pozitif ise yüzey ince kenarlıdır (mercekten dışa doğru, convex).
- ◆ Eğer,  $R_1$  negatif ise ön yüzey kalın kenarlıdır (merceğin içine doğru, concave).
- ◆ Eğer,  $R_1$  sonsuz ise yüzey düzdür, veya sıfır eğrilik vardır, ve düzlem olarak adlandırılır.
- ◆ İşaretleri ters çevirmek suretiyle aynı şeyler merceğin arka yüzü için de geçerlidir:
- ◆ Eğer,  $R_2$  pozitif ise ön yüzey içe doğru (concave), ve eğer,  $R_2$  negatif ise arka yüzey dışa doğrudur (convex).
- ◆ Merceğin yüzeylerini temsil eden kürelerin merkezlerini birleştiren çizgi, merceğin **optik eksenidir** ve merceğin merkezinden geçer.



# İki yüzeyin eğriliklerine göre mercek türleri

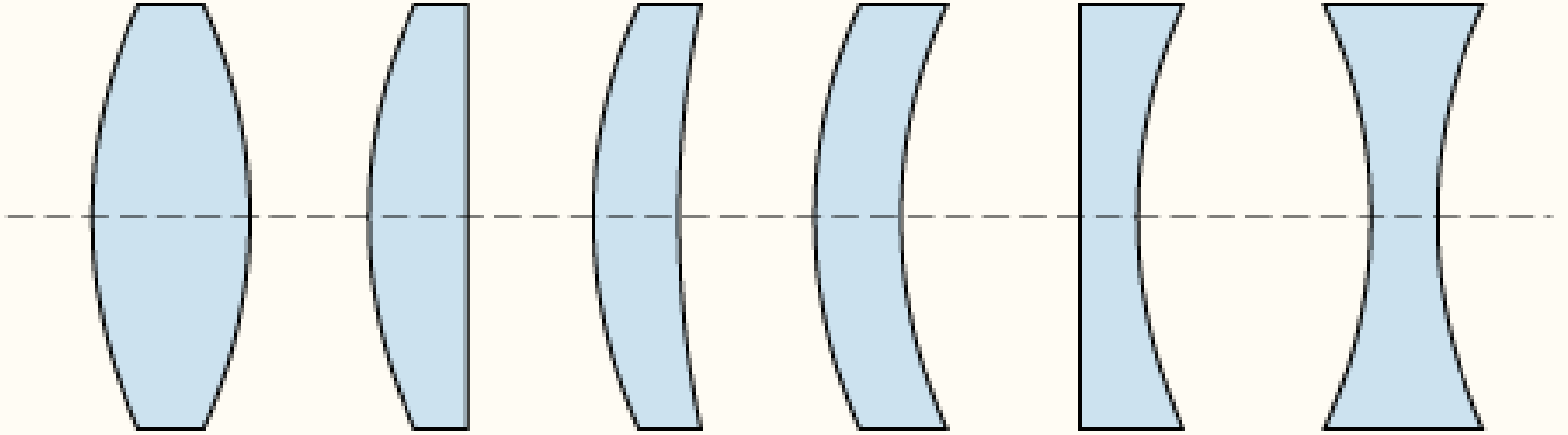

*Biconvex*

*Plano-convex*

*Convex-concave*

*Meniscus*

*Plano-concave*

*Biconcave*

Bir yakınsak (biconvex) merceğe paralel gelen ışınlar, merceğin arka tarafında optik eksen üzerinde belli bir uzaklıkta (**odak uzaklığı**) tek bir noktada (**odak**) kesişecek şekilde kırılır.

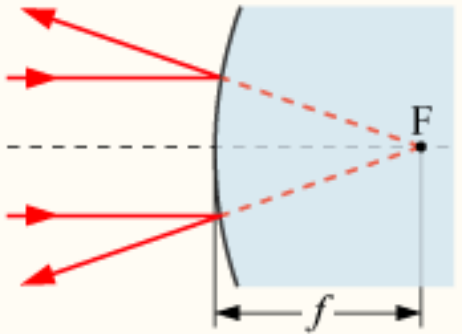
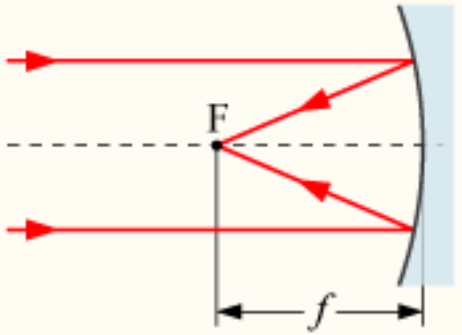
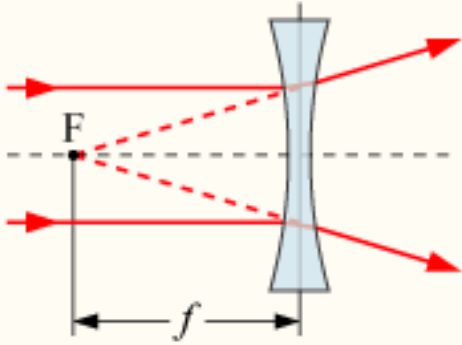
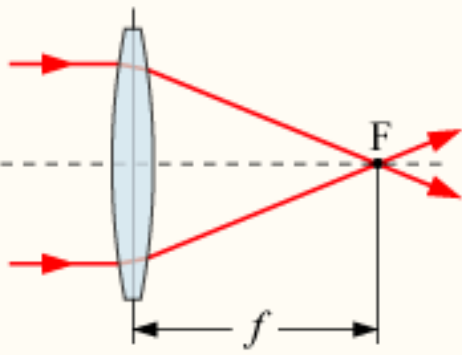

Bir yakınsak (biconvex) merceğe paralel gelen ışınlar, merceğin arka tarafında, optik eksen üzerinde belli bir uzaklıkta ( $f$ : odak uzaklığı, focal length) tek bir noktada (F: odak, focus) kesişecek şekilde kırılır.

# Iraksak (Kalın Kenarlı, Negatif) Mercek

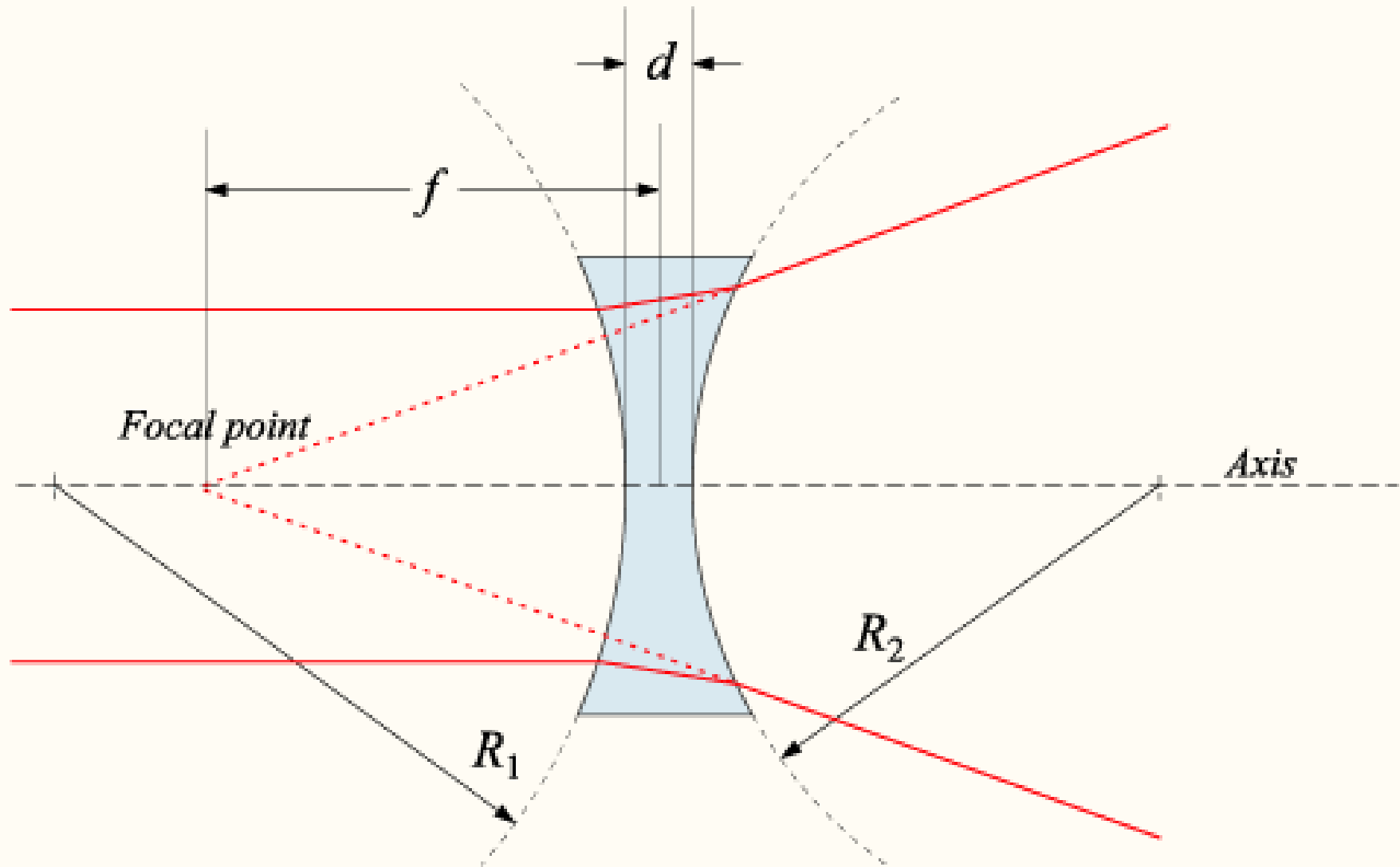

*Negative (diverging) lens*



# Kalın Kenarlı Mercek

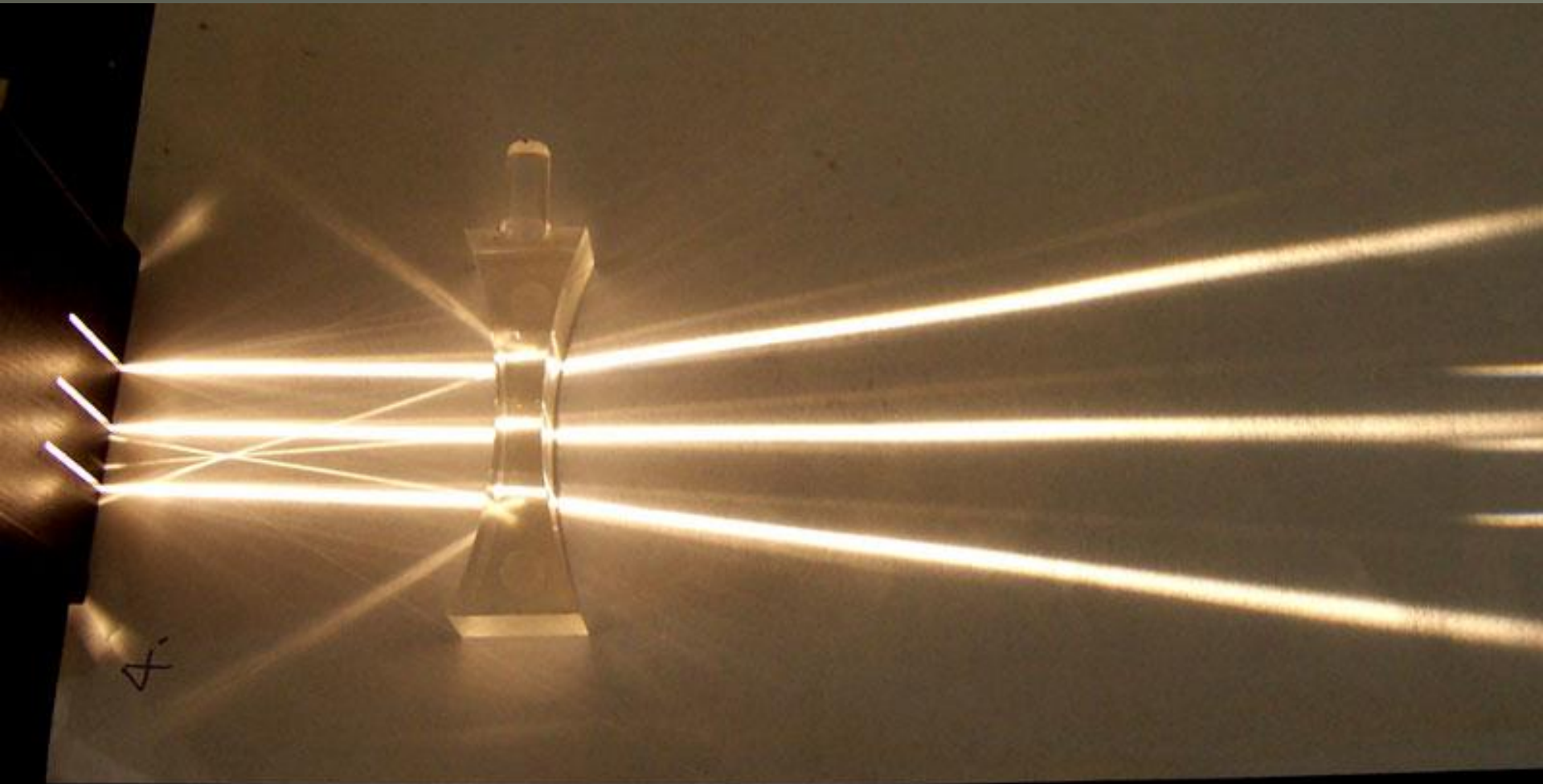

# Özel bir merceğin odak uzaklığı:

$$\frac{1}{f} = (n - 1) \left\{ \frac{1}{R_1} - \frac{1}{R_2} + \frac{(n - 1)d}{nR_1R_2} \right\},$$

burada,  $n$ : mercek maddesinin kırılma indeksi'dir.

$d$ : optik eksen boyunca iki yüzey arasındaki

uzaklık veya merceğin kalınlığıdır.

Eğer,

$d$  yeterince küçükse:

$$\frac{1}{f} = (n - 1) \left\{ \frac{1}{R_1} - \frac{1}{R_2} \right\}.$$

# Odak uzaklığı $f$ :

- ◆ Eğer mercek, yakınsak ise,  $f$ ; pozitiftir.
- ◆ Eğer mercek, ıraksak ise,  $f$ ; negatiftir.
- ◆  $1/f$  : mercek gücü olarak adlandırılır.
- ◆ Mercek gücü, **dioptri** biriminde ölçülür ve birimi  $m^{-1}$  dir.



# Görüntü Özellikleri

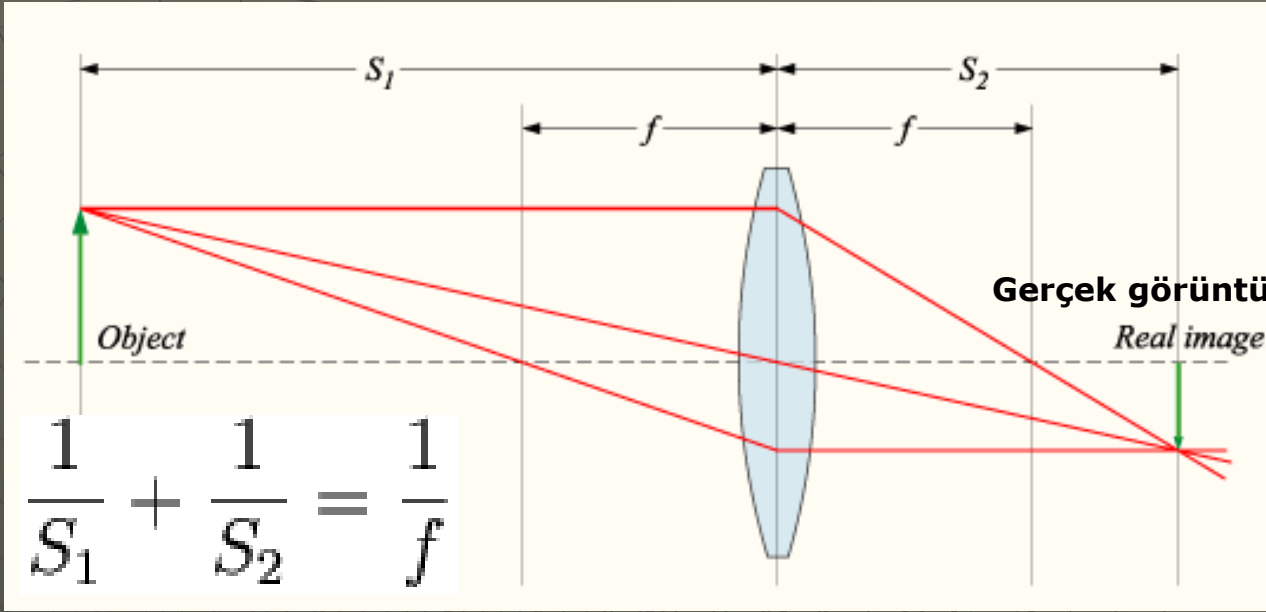

Büyütme gücü:

$S_1 < f$  ise,  $S_2$  negatif olur.

$$M = -\frac{S_2}{S_1} = \frac{f}{f - S_1}$$

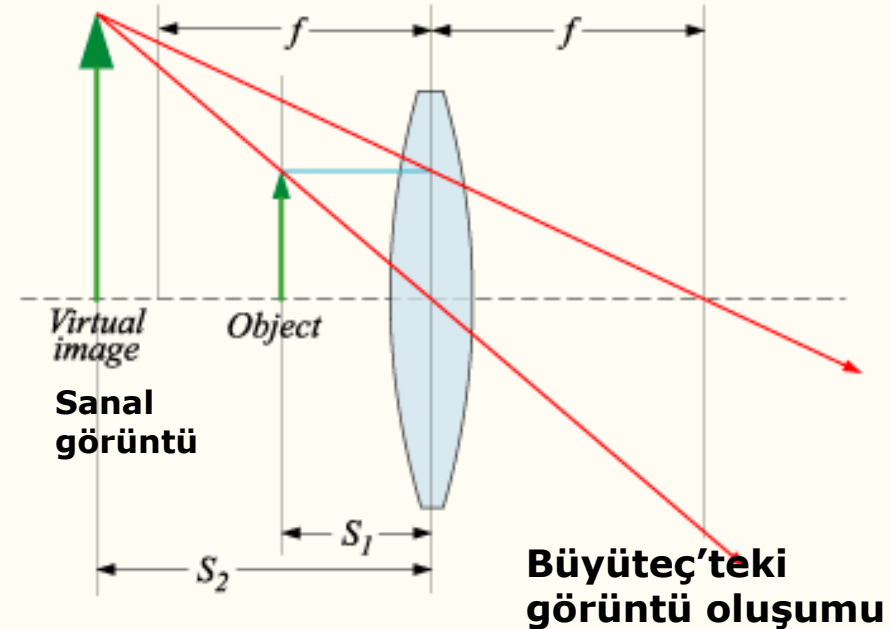

# Iraksak mercek için:

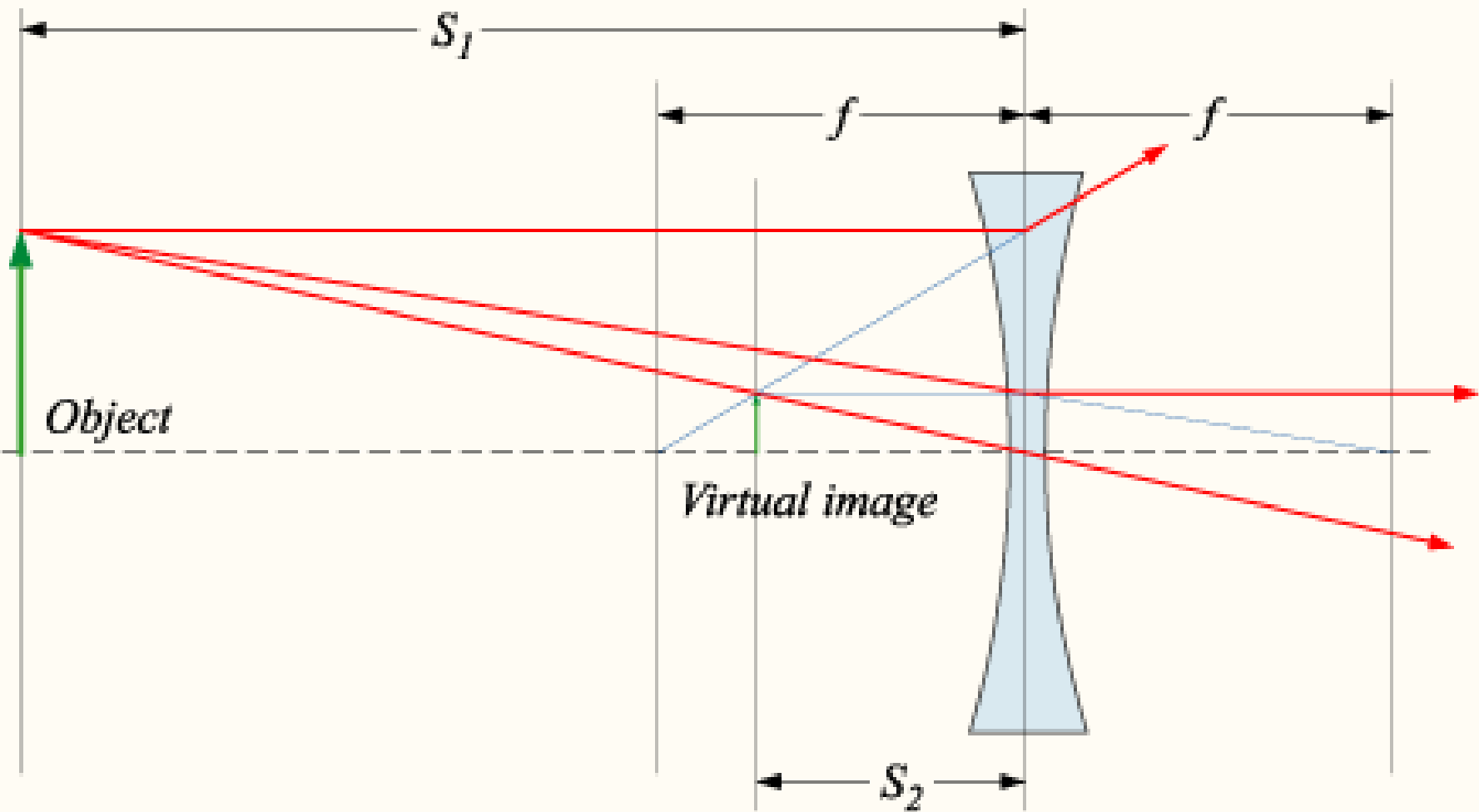

# SAPINÇLAR

(Aberrations)

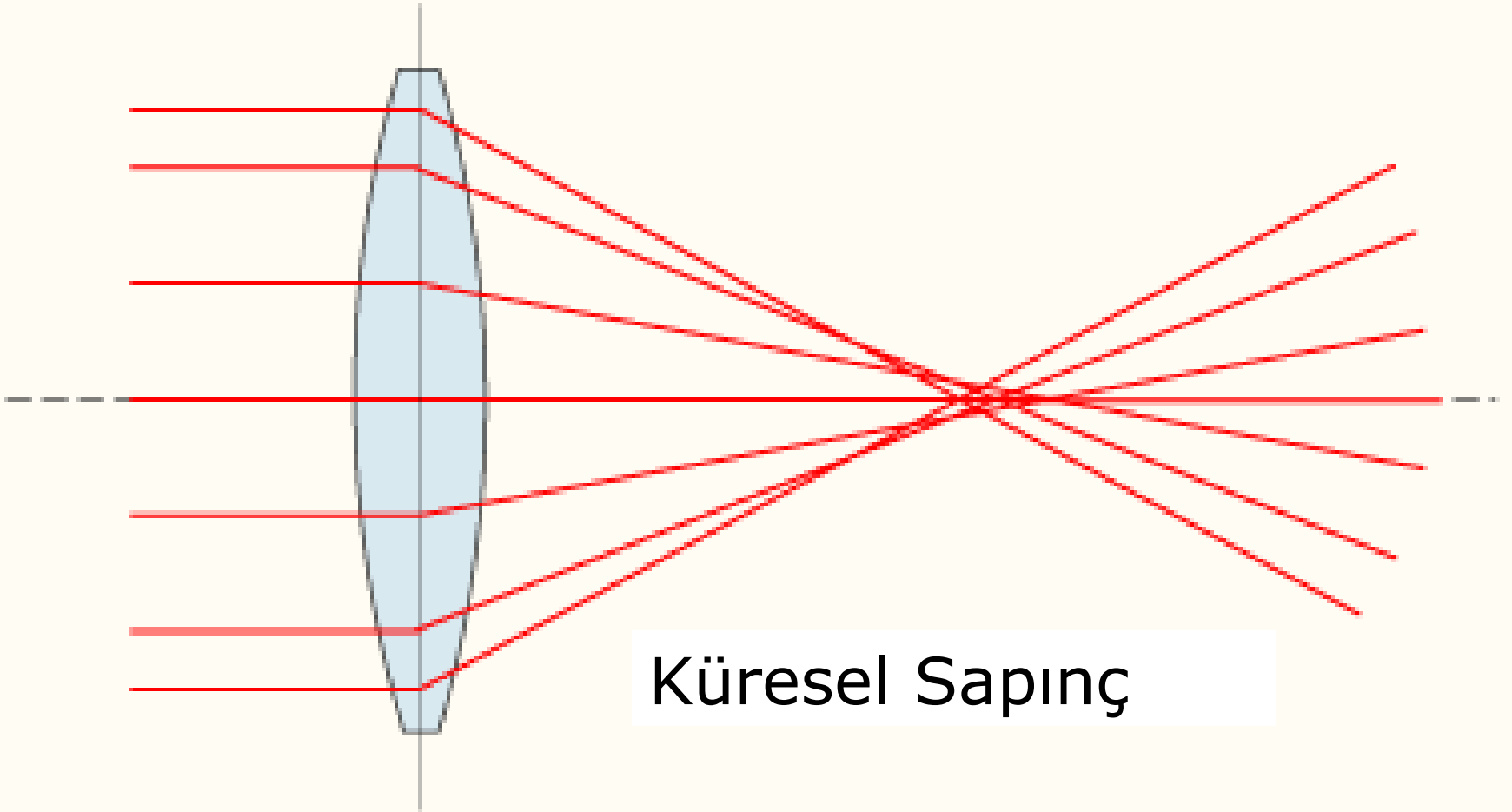

Küresel Sapınc

# Aynalı Teleskoplarda Küresel Sapıncı gidermek için

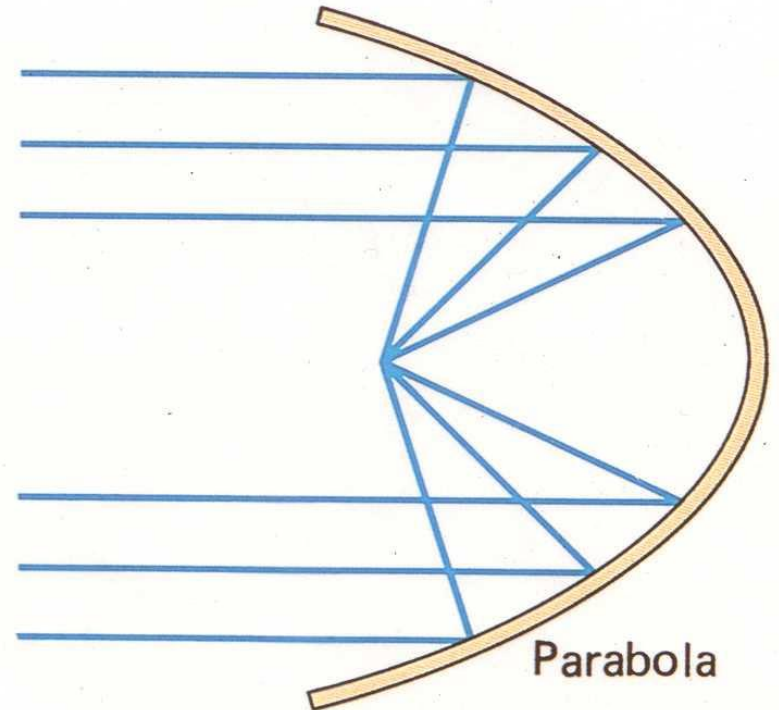
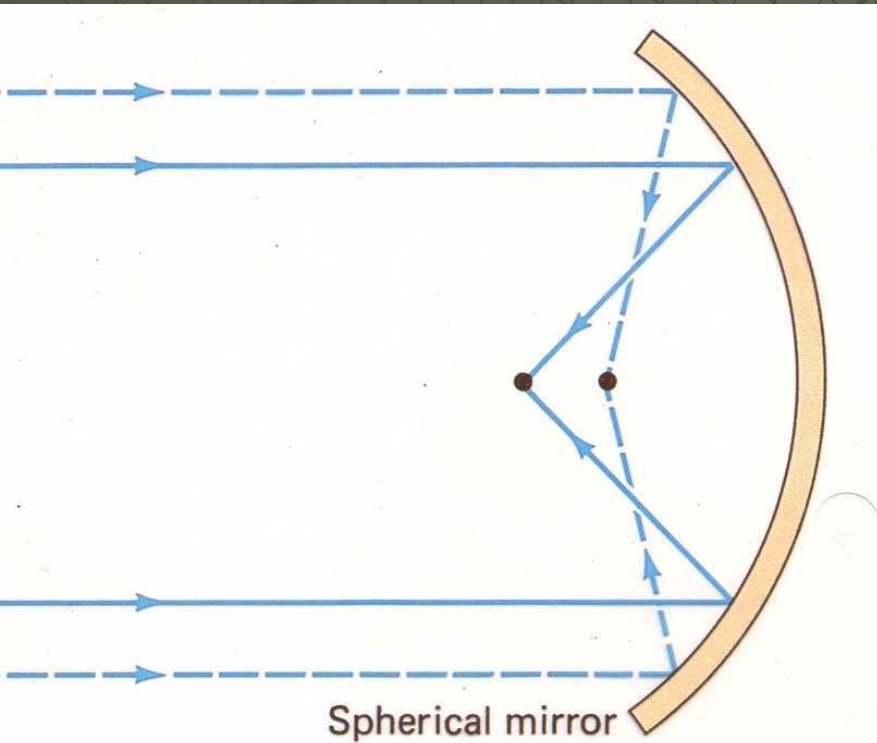
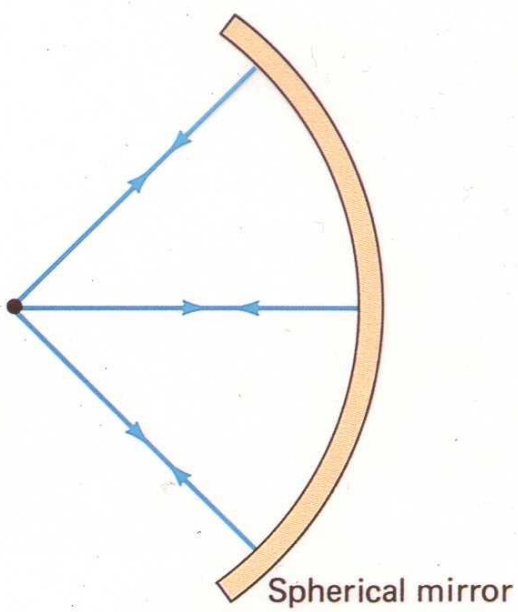



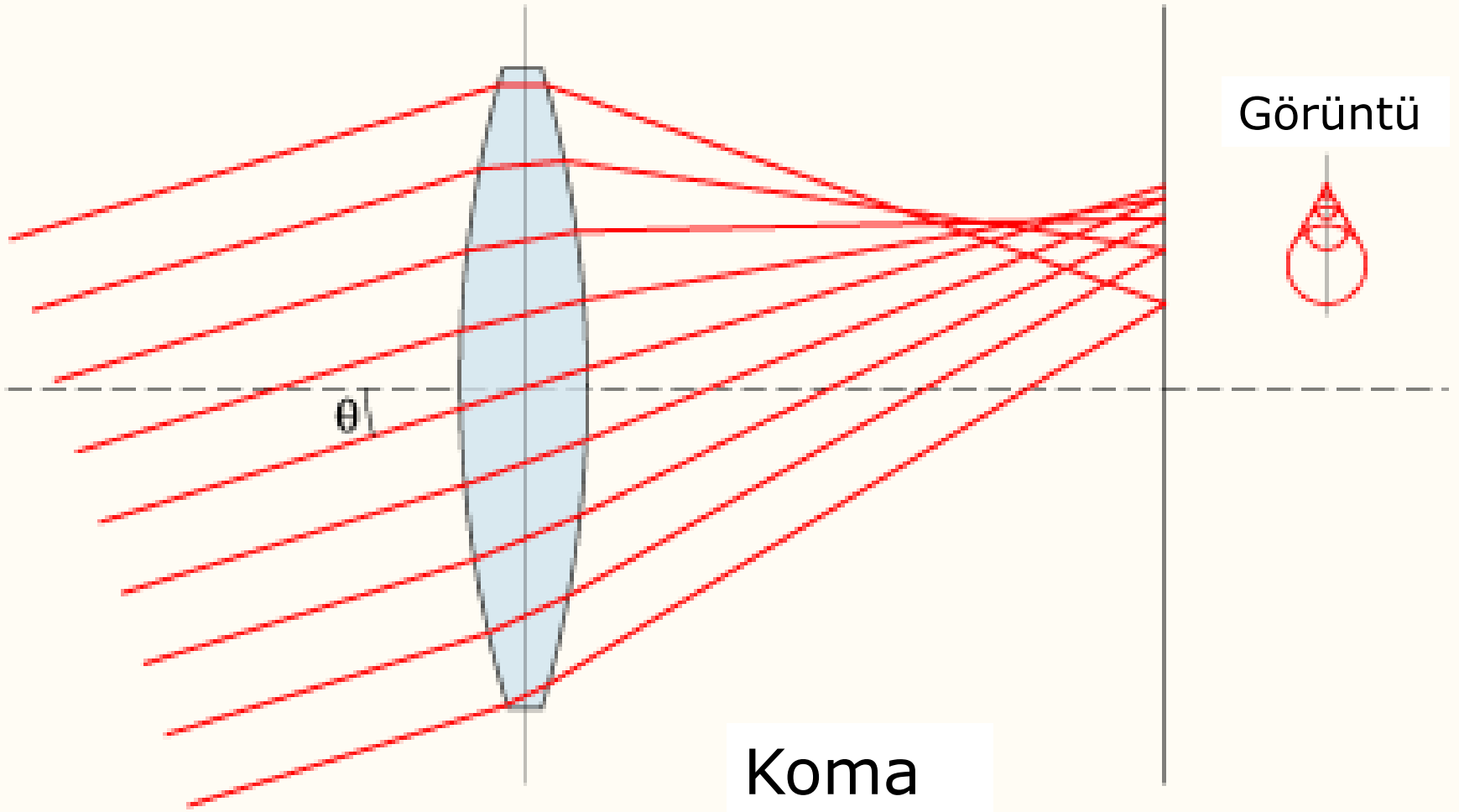

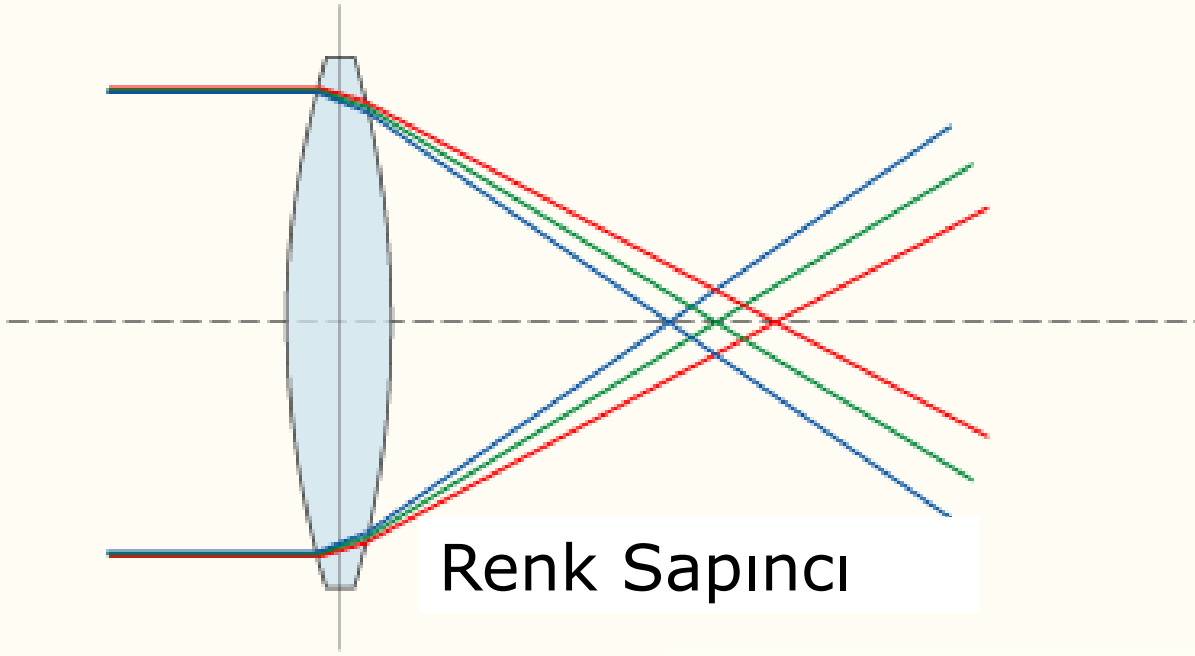

Çoklu mercekler için odak uzaklığı:

$$\frac{1}{F} = \frac{1}{f_1} + \frac{1}{f_2}$$

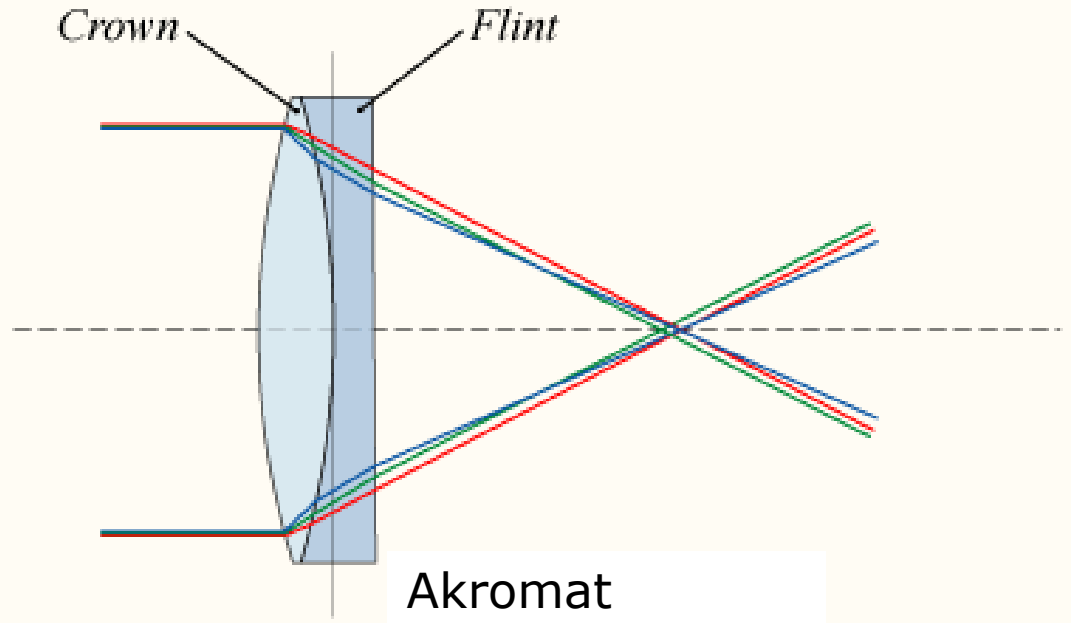

# TELESKOP TÜRLERİ



# 1. Merceklı Teleskop



Uzaktaki cisimleri büyötmek için iki ince kenerlı mercek kullanılır

1. Objektif mercek
2. Göz merceđi

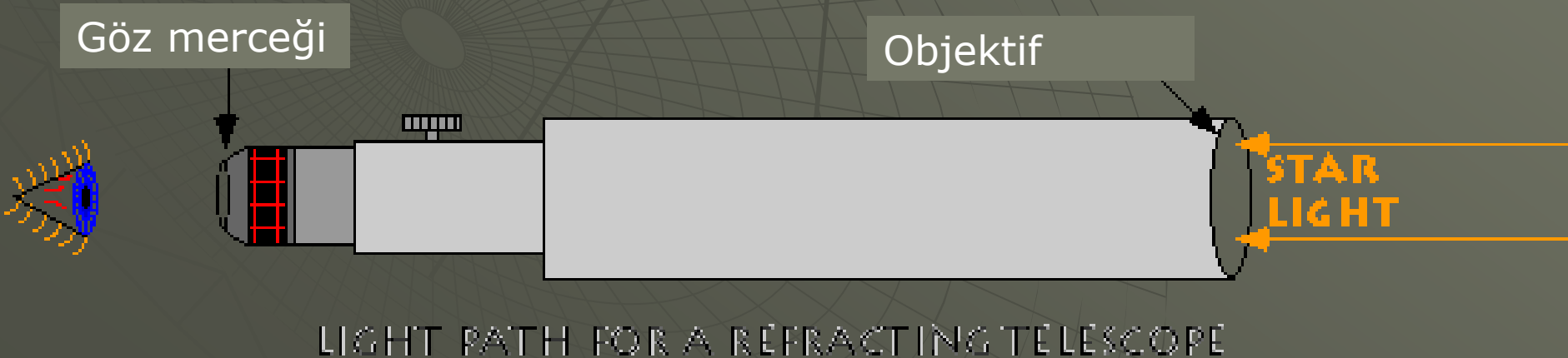

# İnce kenarlı mercekte odak oluşumu

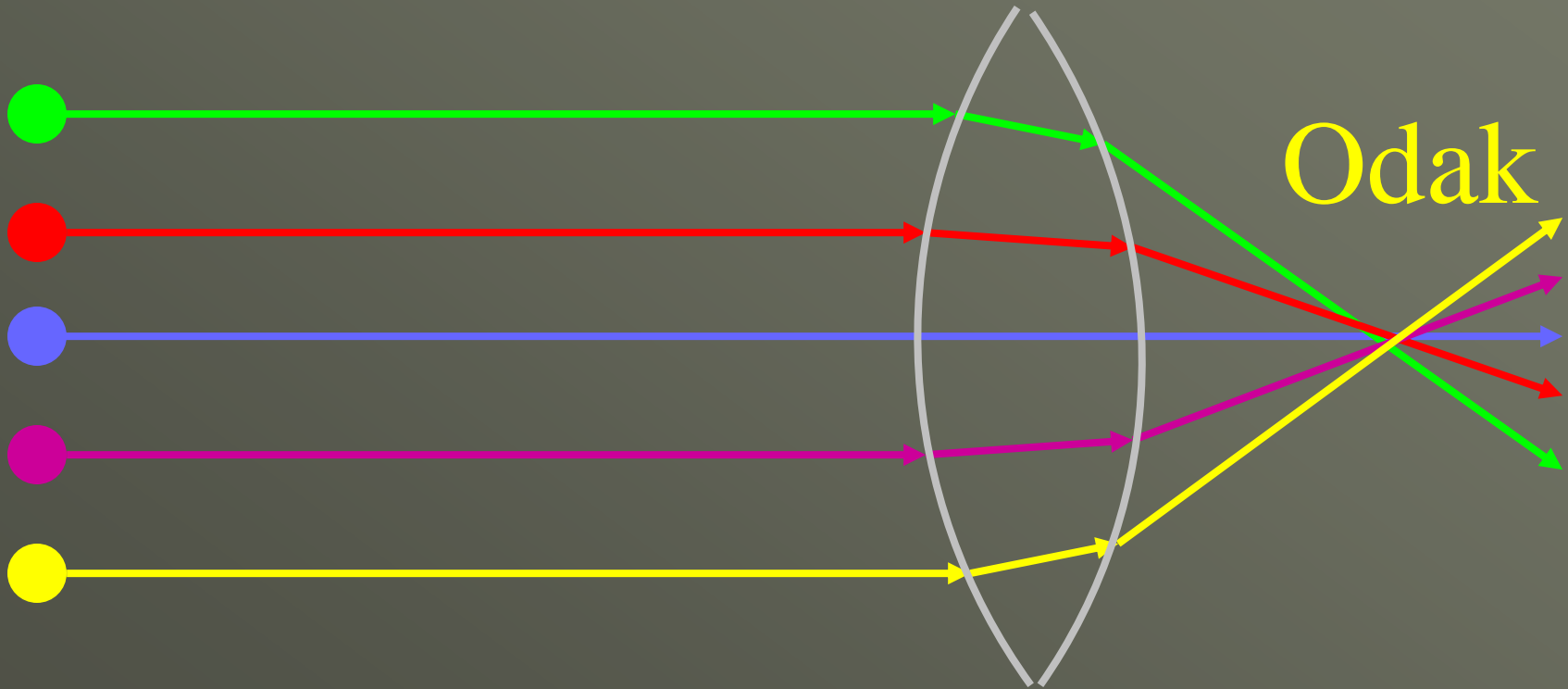



# Yerkes Gözlemevi

1 m. çaplı  
mercekli teleskop,

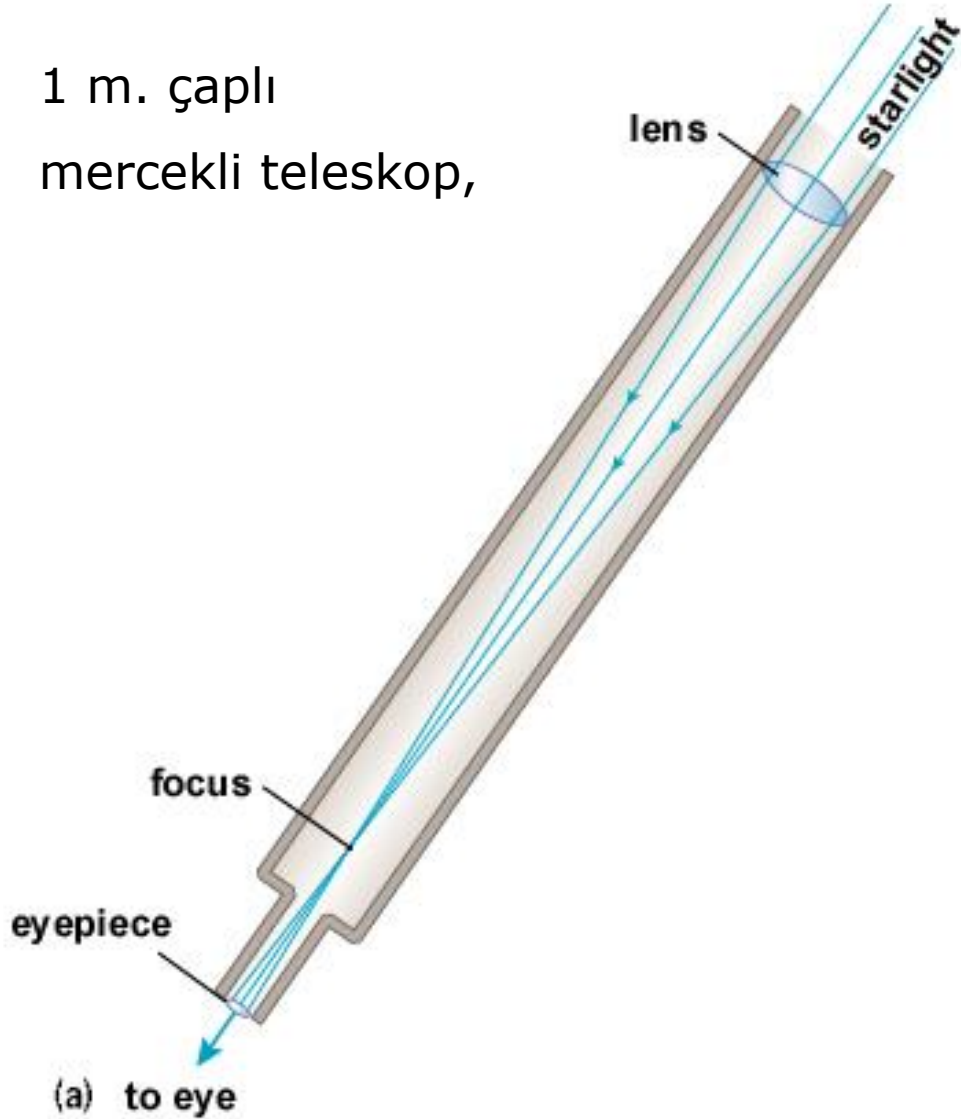

(b)



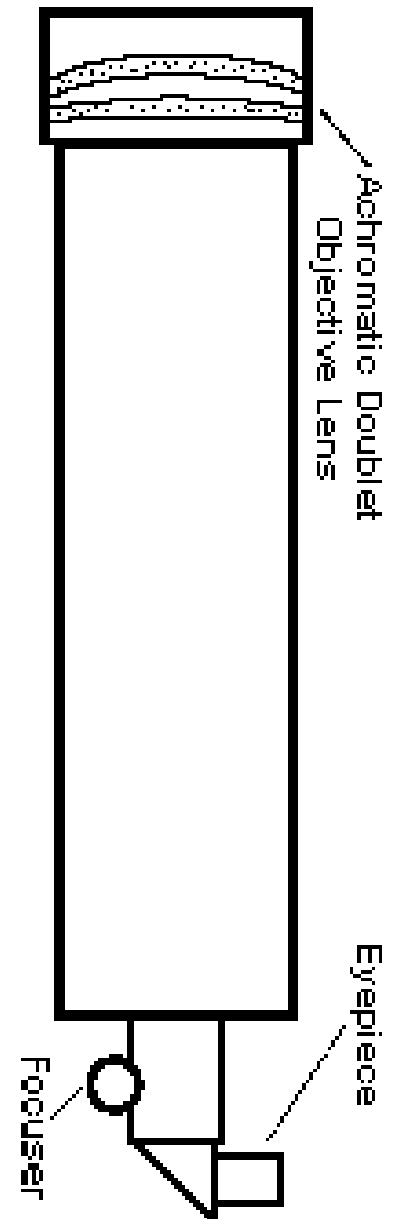
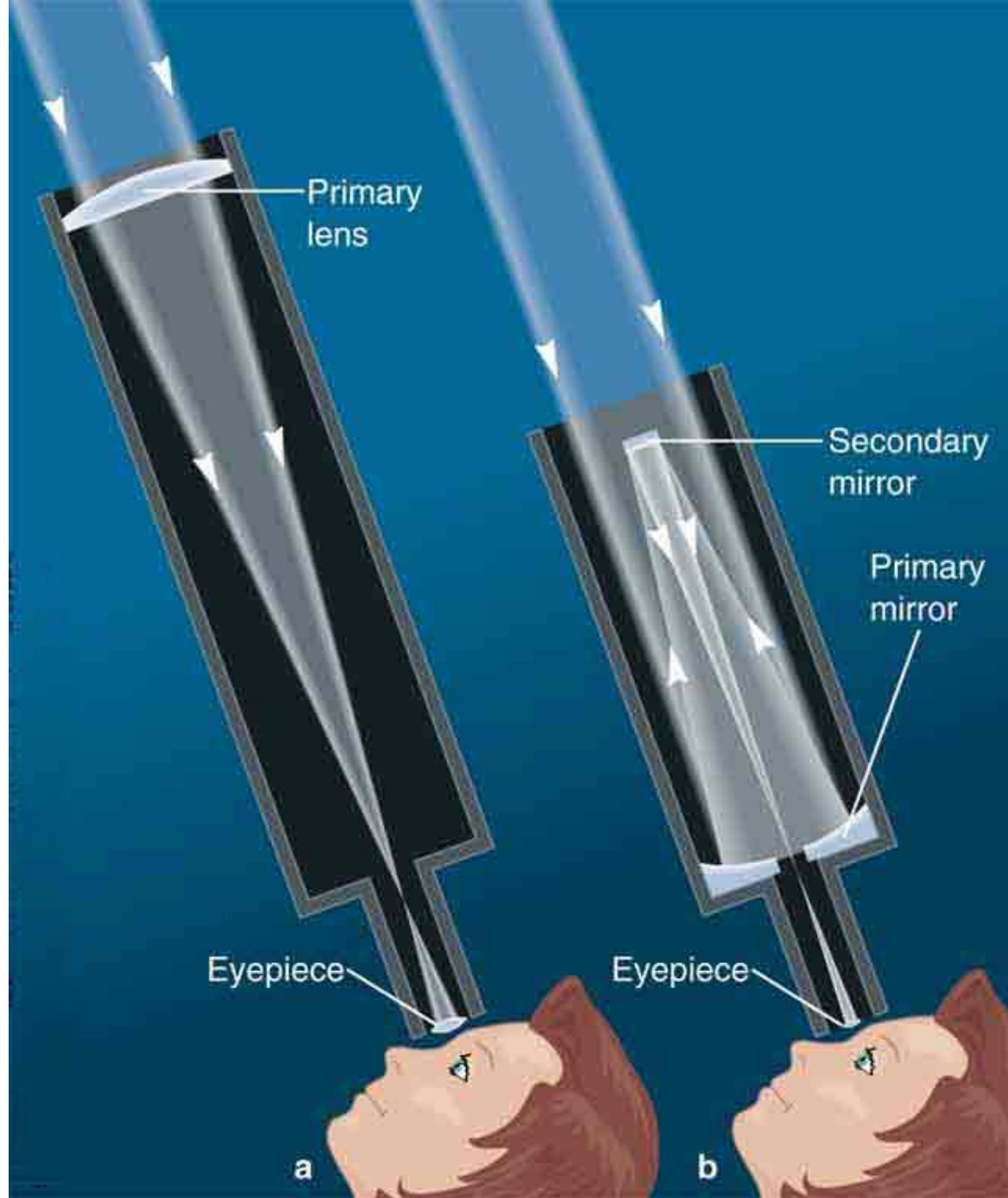

# Küçük merceklı teleskoplar



# 2. Aynalı Teleskop

## a. Newtonian Teleskop

Çukur ayna, düzlem ayna ve bir göz merceği kullanılır

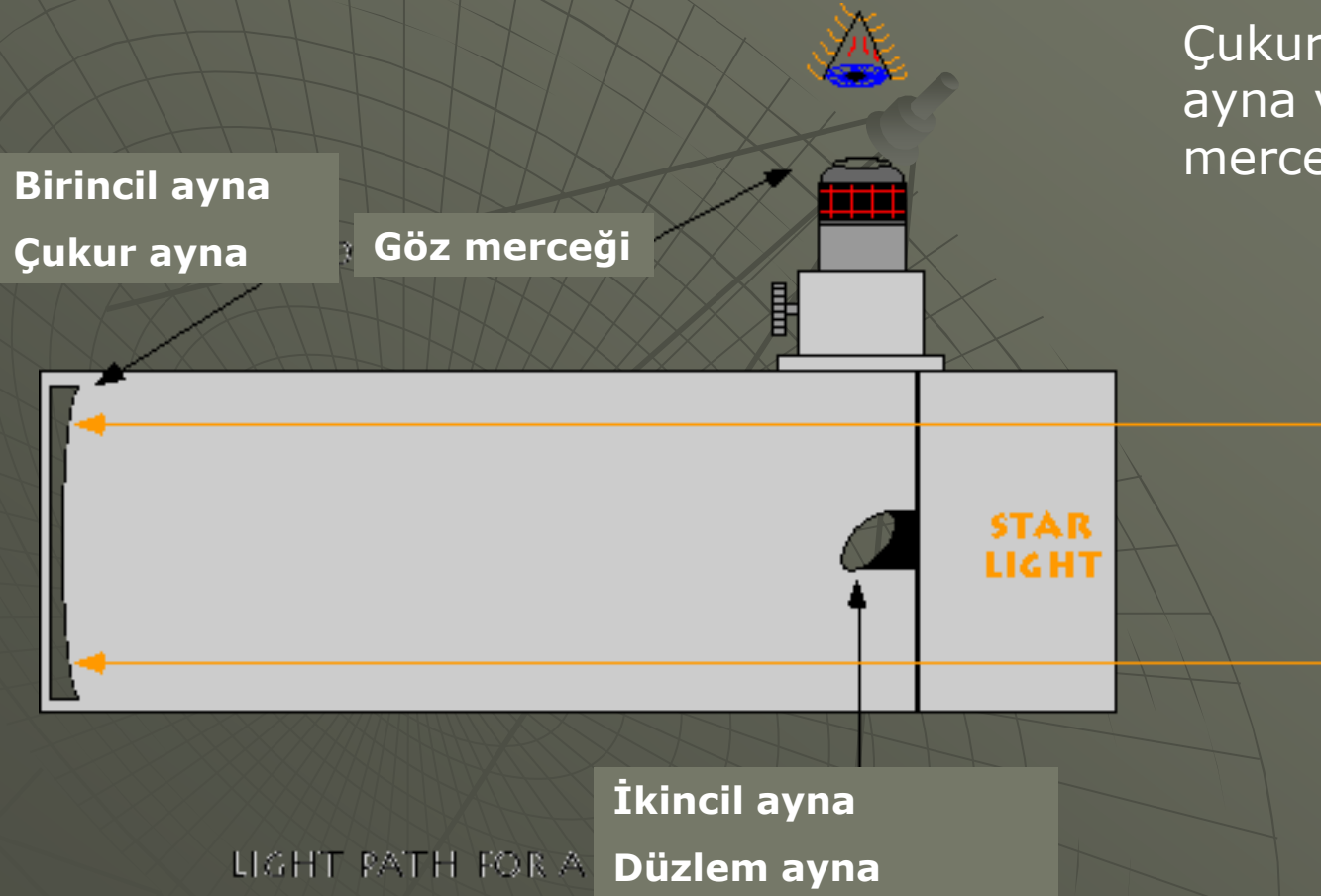



# Çukur aynada odak oluşumu

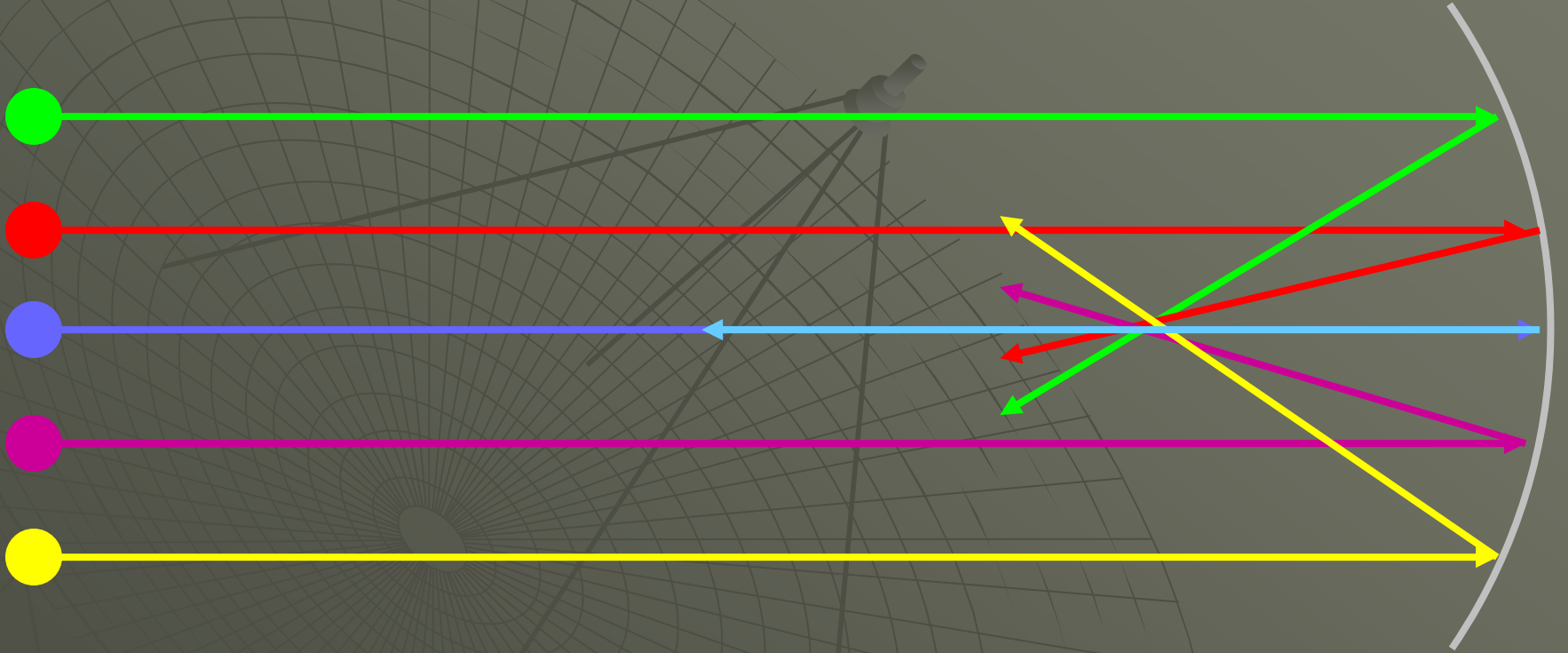



# Newtonian focus

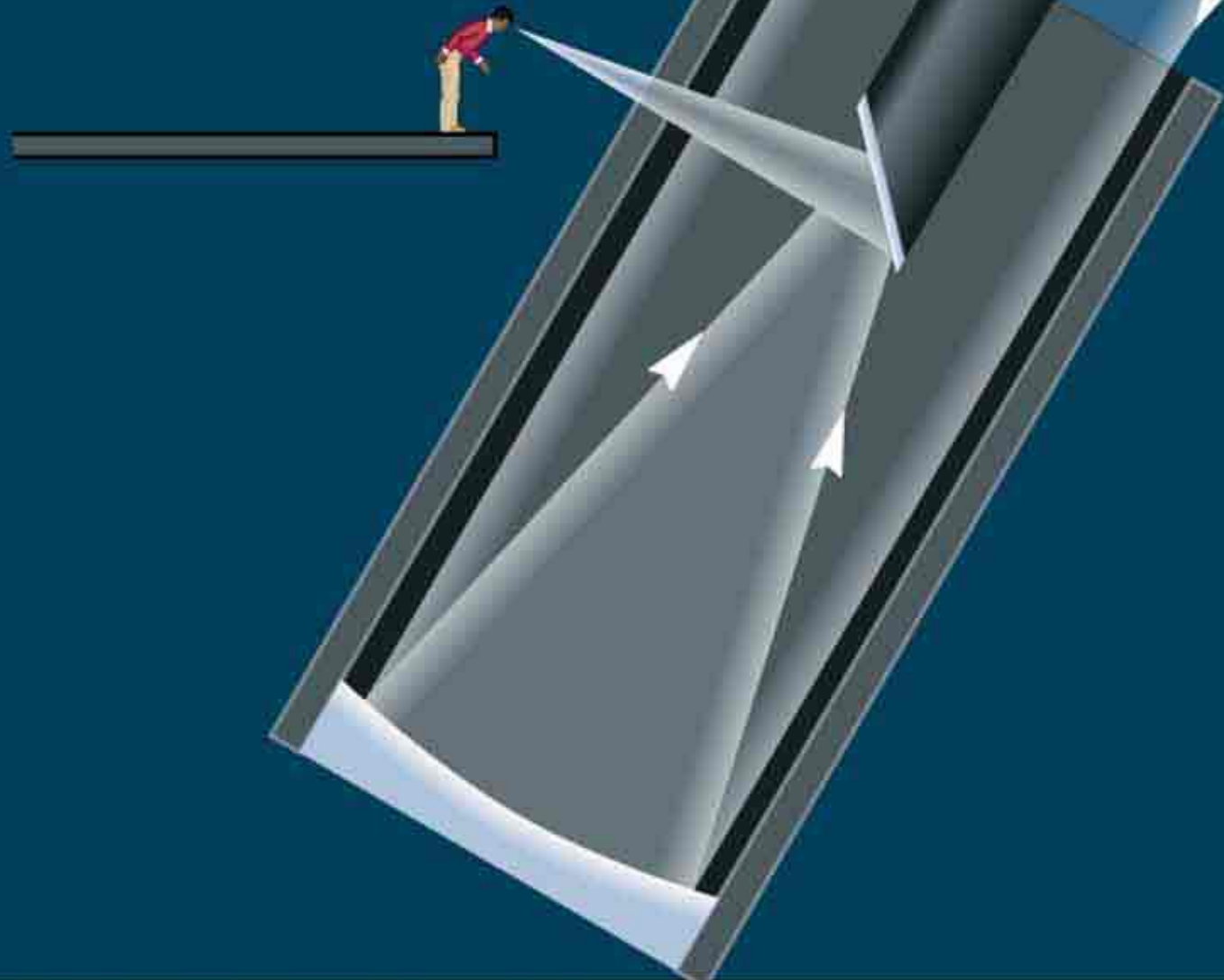

# Dobsonian Teleskobu

John Dobson tarafından  
dizayn edilmiştir



# İlk Teleskoplar



Galileo'nun mercekli teleskobu



Newton'un aynalı teleskobu



# İlk Büyük Teleskoplar

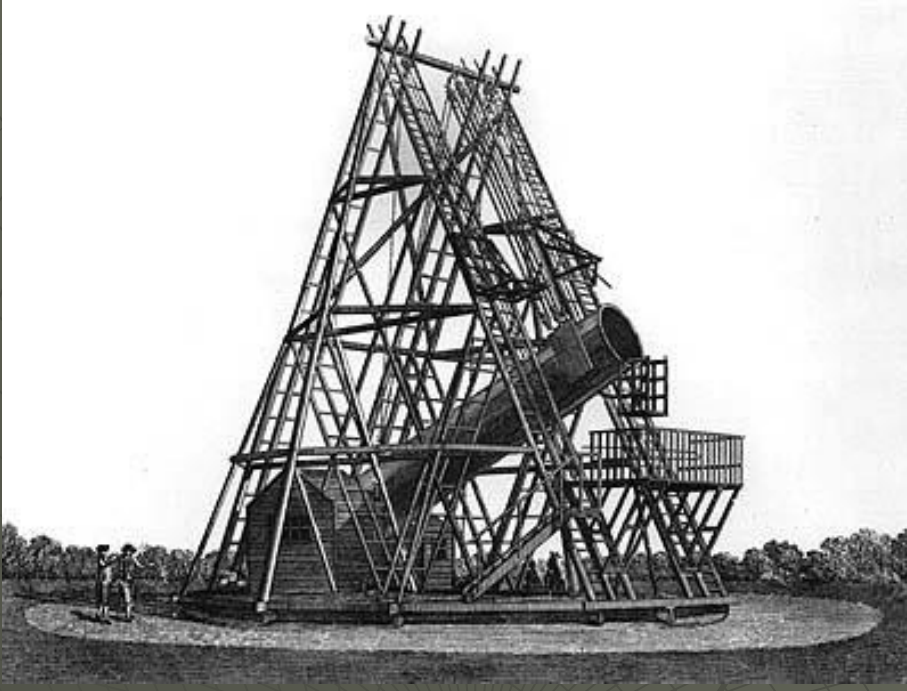

William Herschel'in  
en büyük teleskobu  
1700'lerin sonu



Lord Rosse'nin  
teleskobu (1840)

## b. Cassegrain Teleskop

Birincil çukur ayna, ikincil tümsek ayna ve göz merceği kullanılır.

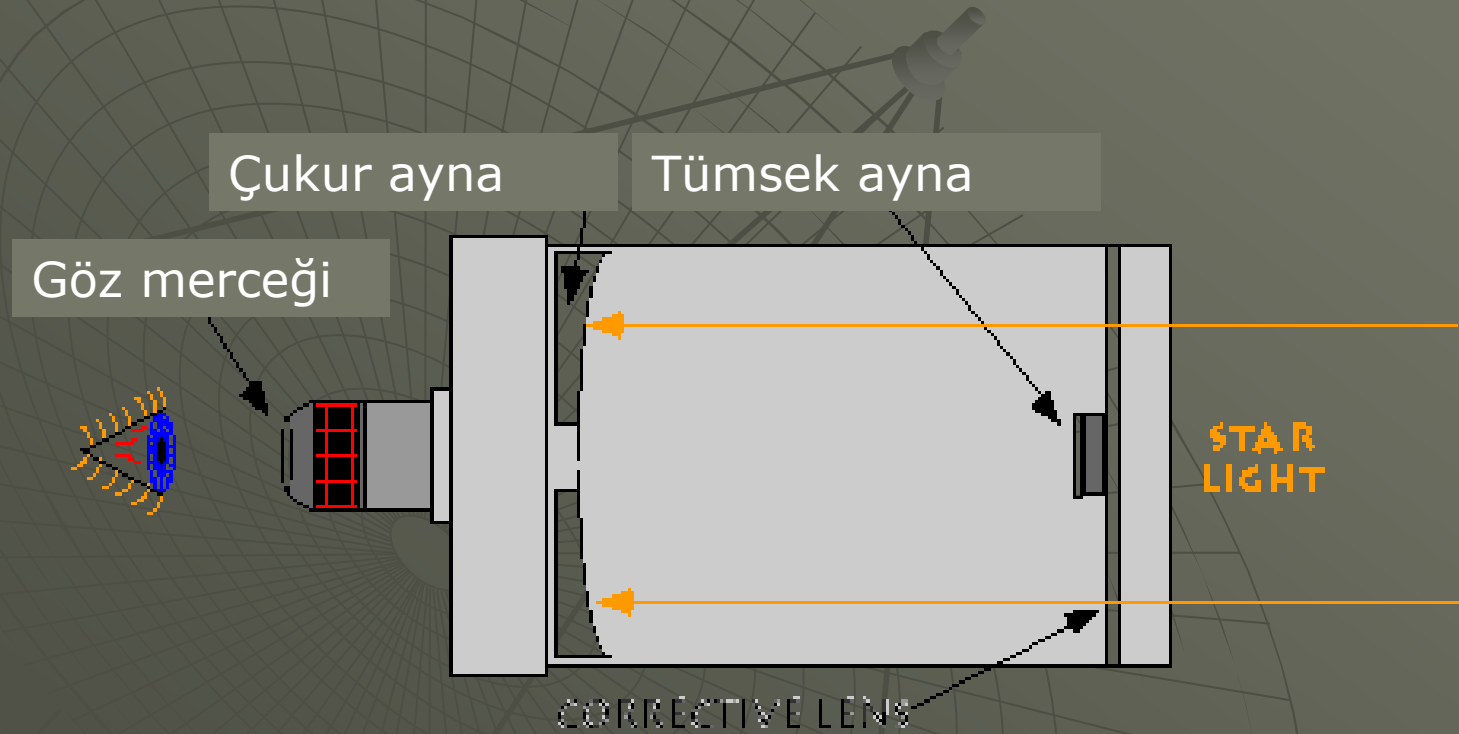

LIGHT PATH FOR A CATADIOPTRIC TELESCOPES



# Cassegrain Teleskop

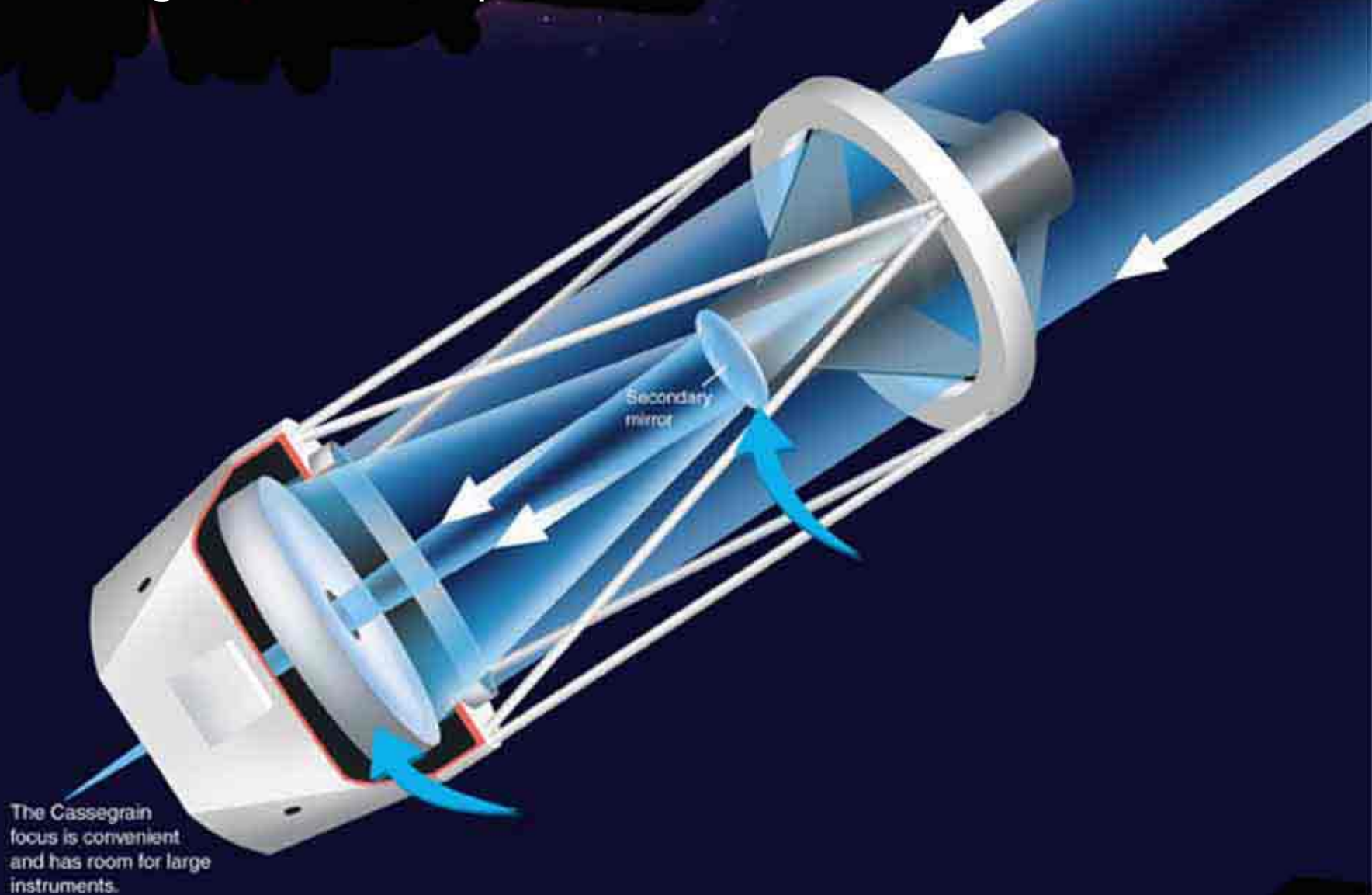

Ege Üniversitesi Gözlemevi,  
Cassegrain türü teleskop- 48 cm



15/07/2004



# 48 cm'lik teleskobun parabolik aynası







© 2004 Thomson/Brooks Cole

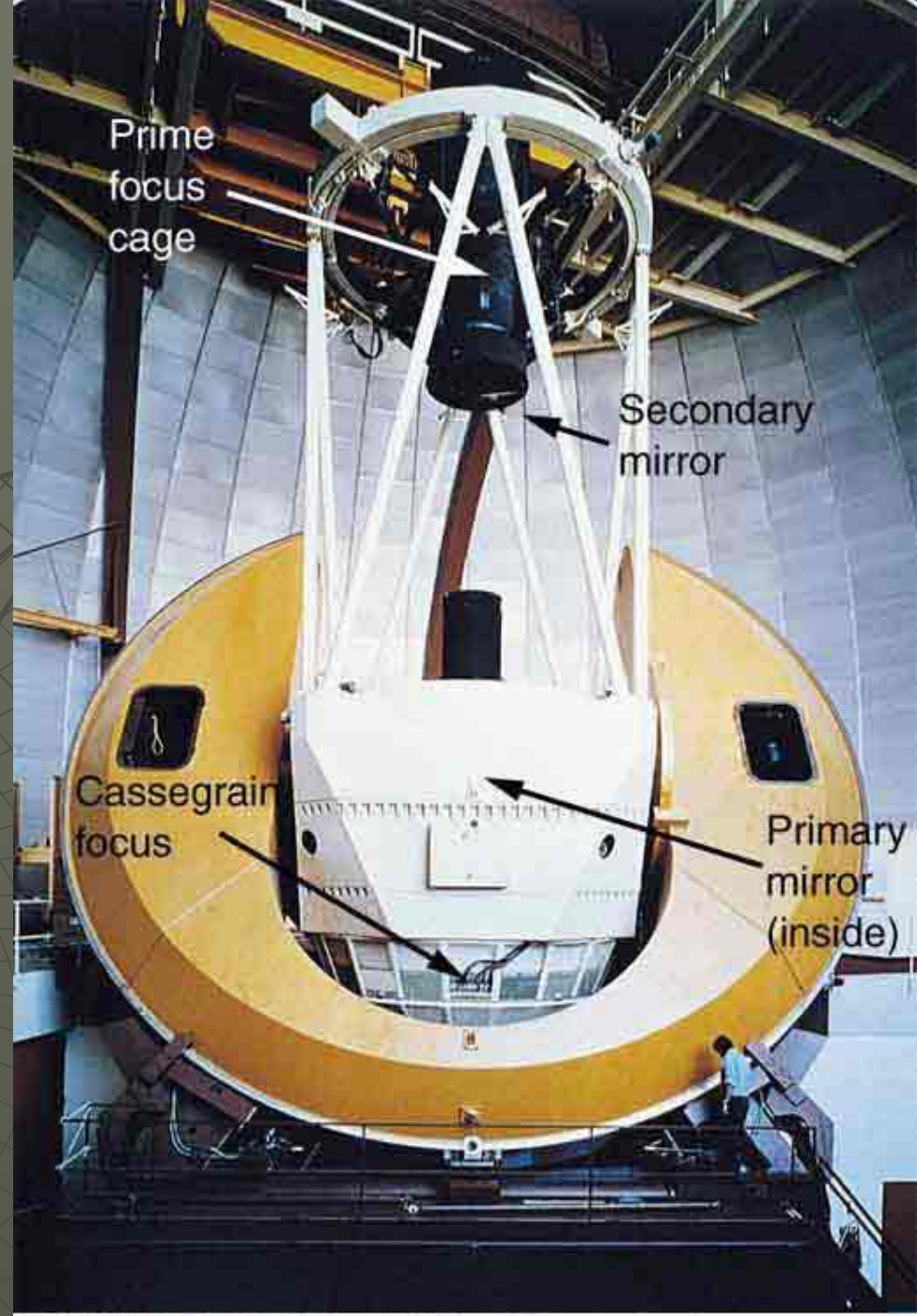

© 2004 Thomson - Brooks Cole

# 3. Katadioptrikler

- ◆ Ayna ve mercekleri aynı anda kullanan teleskoplardır.

Türleri:

- ◆ Schmidt-Cassegrain
- ◆ Maksutov-Cassegrain
- ◆ Schmidt-Newtonian



# 35 cm Schmidt-Cassegrain

Ege Üniversitesi Gözlemevi



© 2004 Thomson - Brooks Cole



Teleskobun  
önünde  
güneş filtresi

14/07/2004

# Aynalı Teleskoplarda Değişik Odaklar

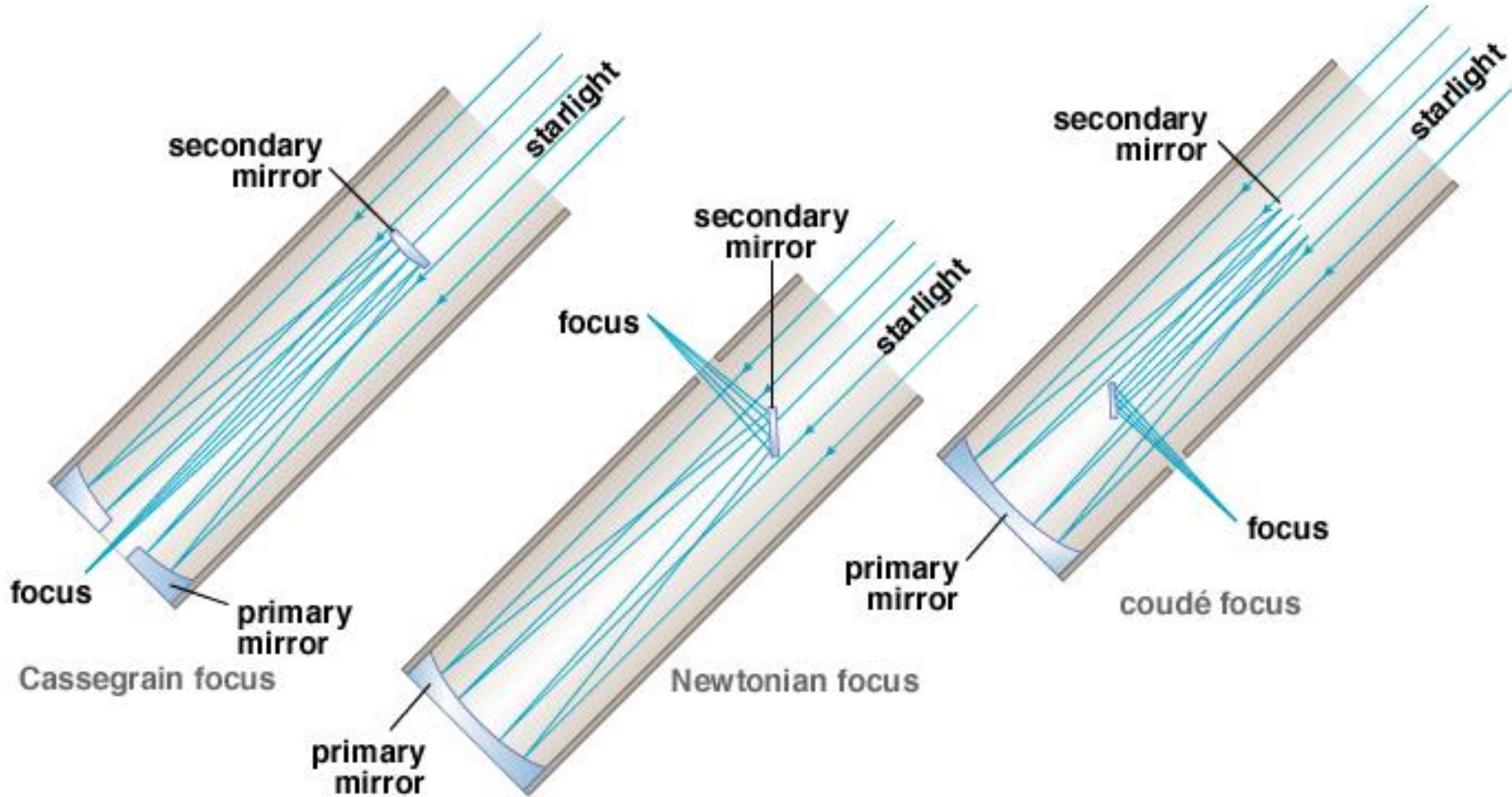





# TELESKOBUN ÜÇ FONKSİYONU

# Neden teleskop kullanırız?

- ◆ Daha parlak görmek için
- ◆ Daha büyük görmek için
- ◆ Daha iyi çözümlenebilmek için





Düşük

Yüksek

## *Işık Toplama Gücü*

(Light Gather Power)



Düşük

Yüksek

## *Büyütme*

(Magnification)



Düşük

Yüksek

## *Çözümleme*

(Resolution)

# Işık Toplama Gücü

- ◆ Işık Toplama Gücü, objektif alanı ( $\pi r^2$ ) ile ilişkilidir.

r: Objektifin Yarıçapı

# Teleskopların Işık Toplama Alanları

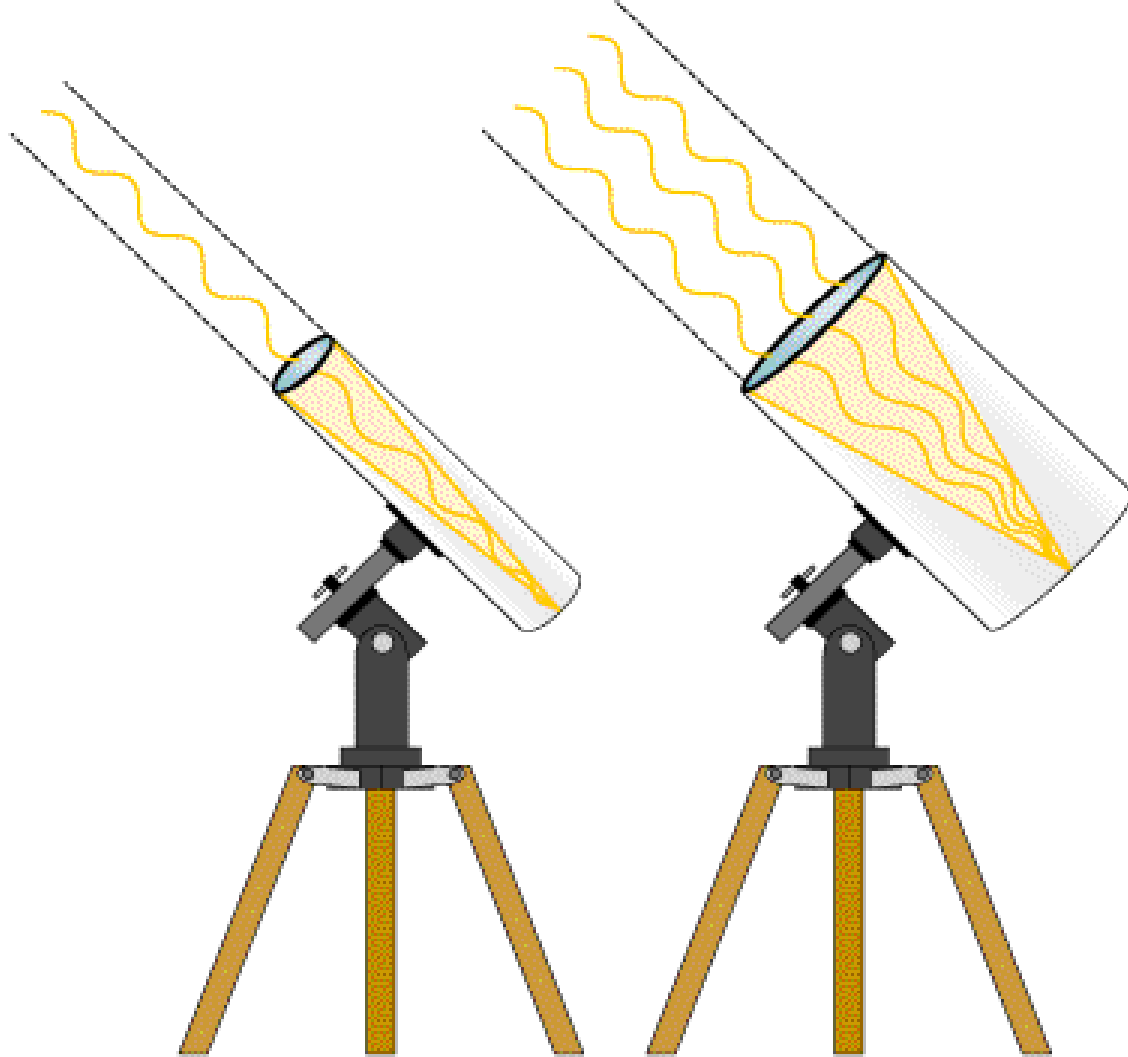

# Büyütme Gücü

$$\text{Büyütme} = \frac{\text{Objektif merceğin veya aynanın odak uzaklığı}}{\text{Göz merceğinin odak uzaklığı}}$$

BÜYÜTME ARTTIKÇA, GÖRÜNTÜ BULANIKLAŞIR



# Açısal Çözümleme

- ◆ Bir görüntüdeki ayrıntıları daha iyi görebilme.
- ◆ Daha büyük objektif çaplı teleskoplar daha küçük cisimleri ayırt edebilir.
- ◆ Hubble Uzay Teleskobu'nun çözümleme gücü 0.05 yaysaniyesidir.

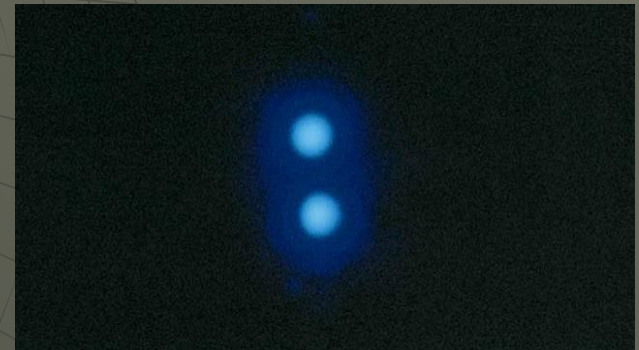
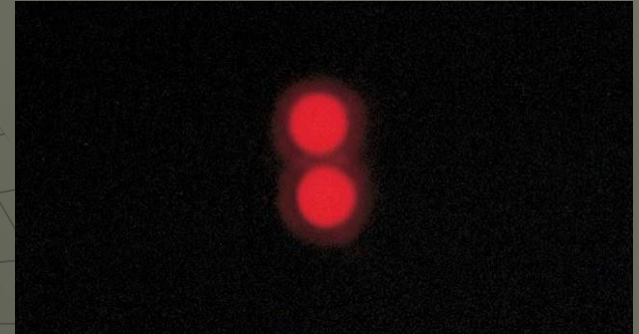
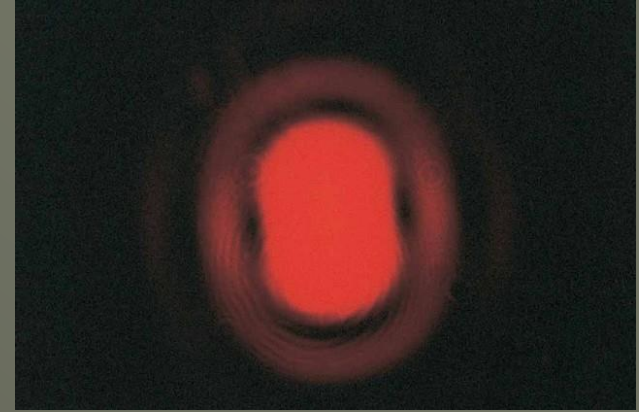



$$\theta_R = \frac{252000 \times \lambda(\text{cm})}{D(\text{cm})}$$

$\lambda$ : Dalgaboyu

D: Objektifin çapı

$\theta_R$ : Açısal çözümüleme (ayırma) gücü

# ODAK ORANI

$f/\text{oran} = \text{odak uzaklığı} / \text{çap}$

$f/10, f/8$

# ATMOSFERİN GÖZLEMLERE ETKİSİ

- ◆ **Işık Kirliliği** (Light Pollution)  
Gece, şehir ışıklarının saçılması.  
Sönük yıldızların görünmesini engeller.  
"Görüş" ü düşürür (seeing).

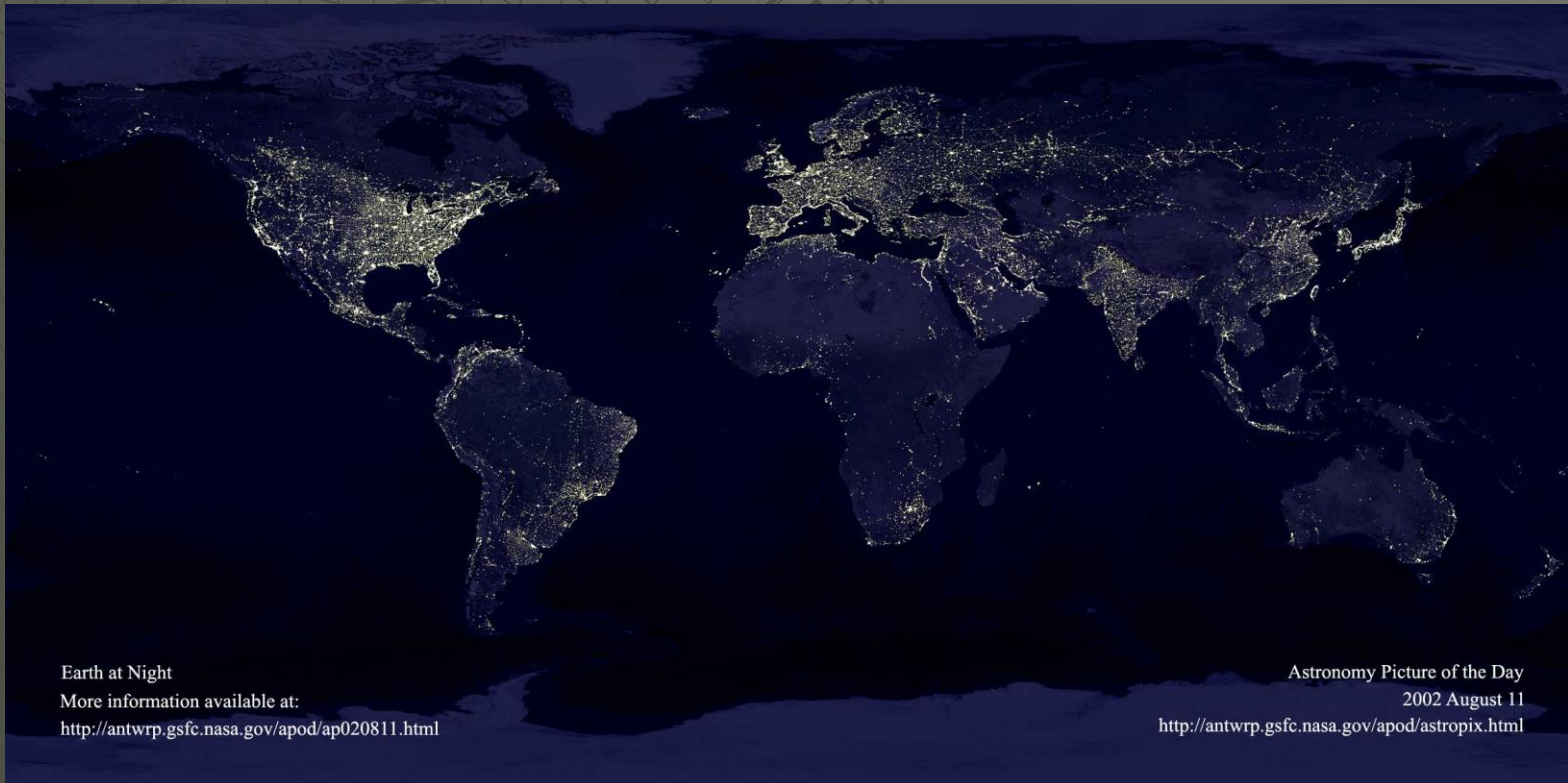

# Sönükleştirme, Saçılma, Kırılma

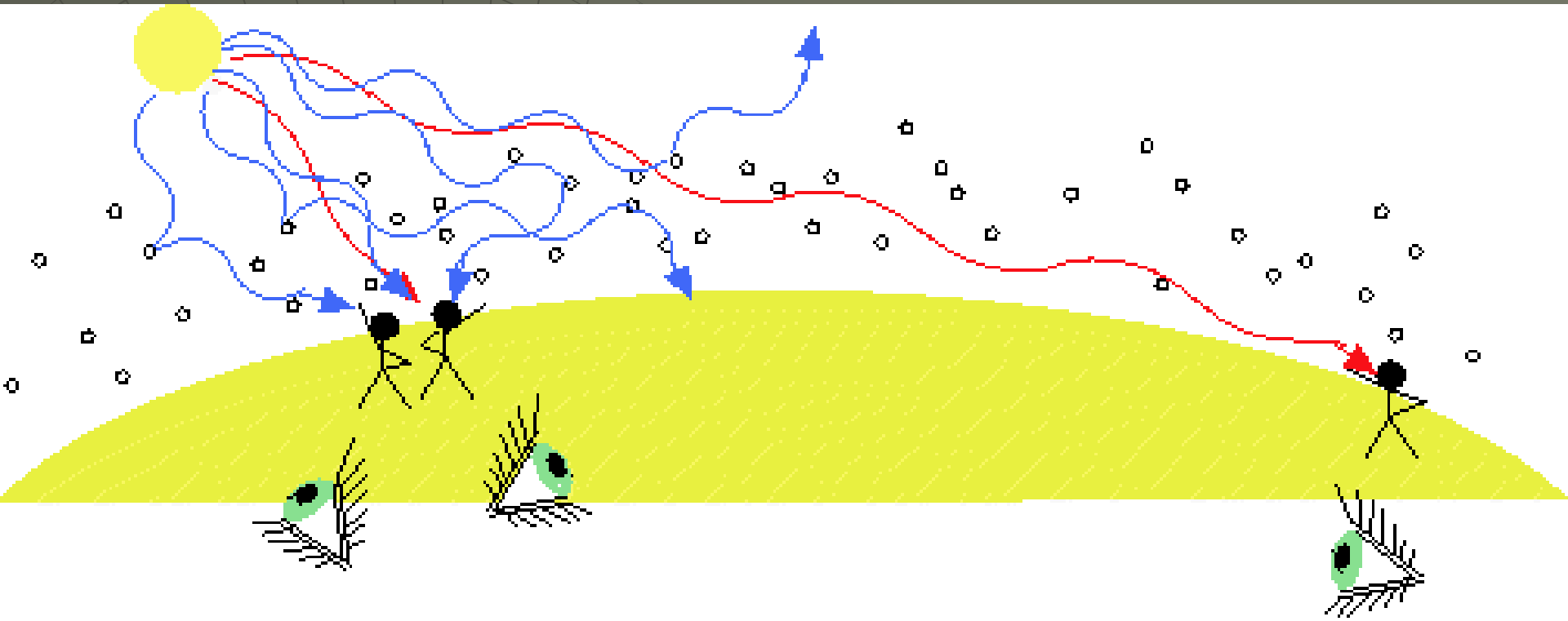

<http://www.astronomynotes.com/telescop/s12.htm>

Teleskoptaki  
Görüntü

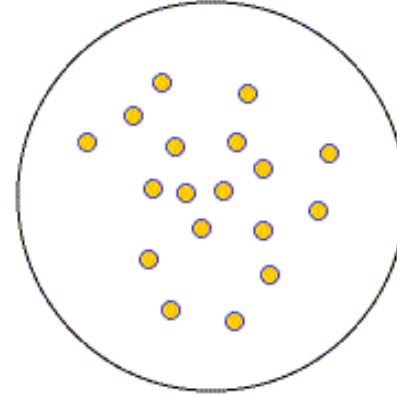
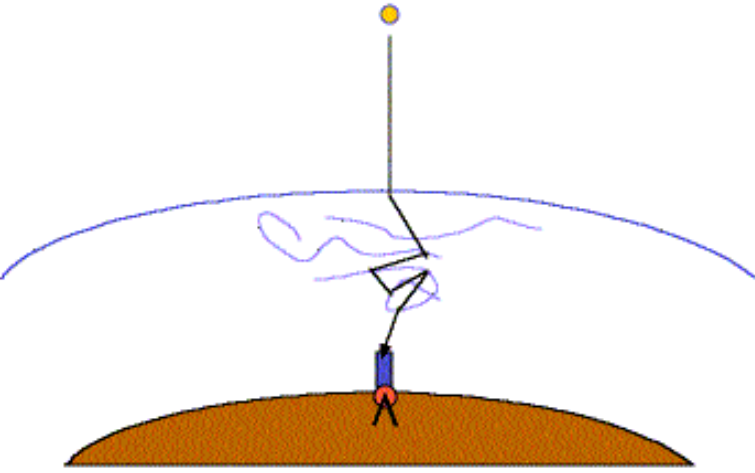

◆ **Çalkantı**  
(Turbulence)

- ◆ Teleskop yakınındaki veya atmosferdeki hava hareketleri, ışığı kırar ve görüntüde kaymalar ve titremeler oluşturur.

Teleskoptaki  
Görüntü

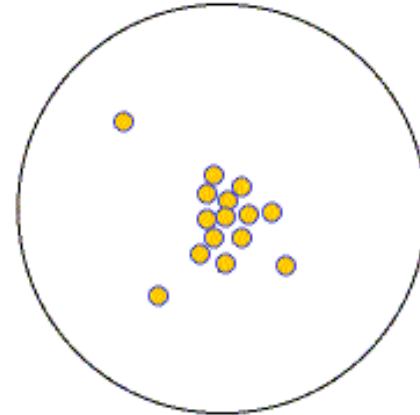
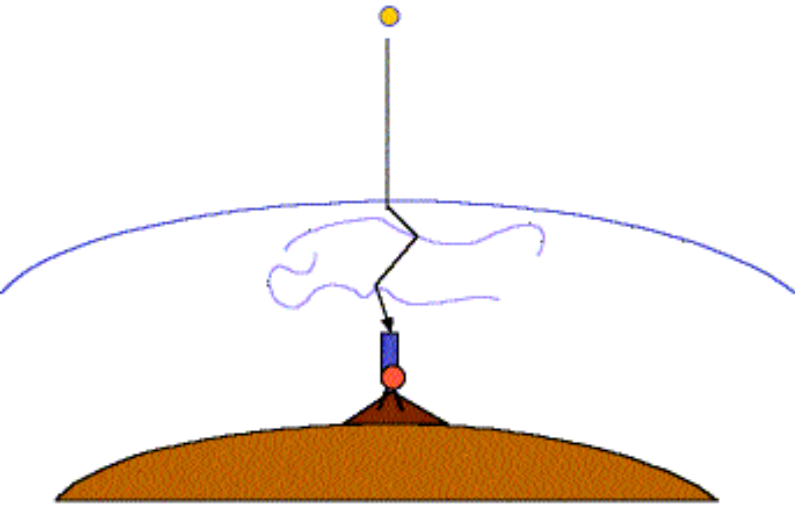



# Atmosfer etkisinden kurtulmanın bir yolu

- ◆ **Adaptive Optics**, atmosferik bozulmaların bir çoğunu boşlayabilir.
- ◆ Birincil aynanın “kontrollü bozulmuş” yapısı, etkileri yokedebilir.

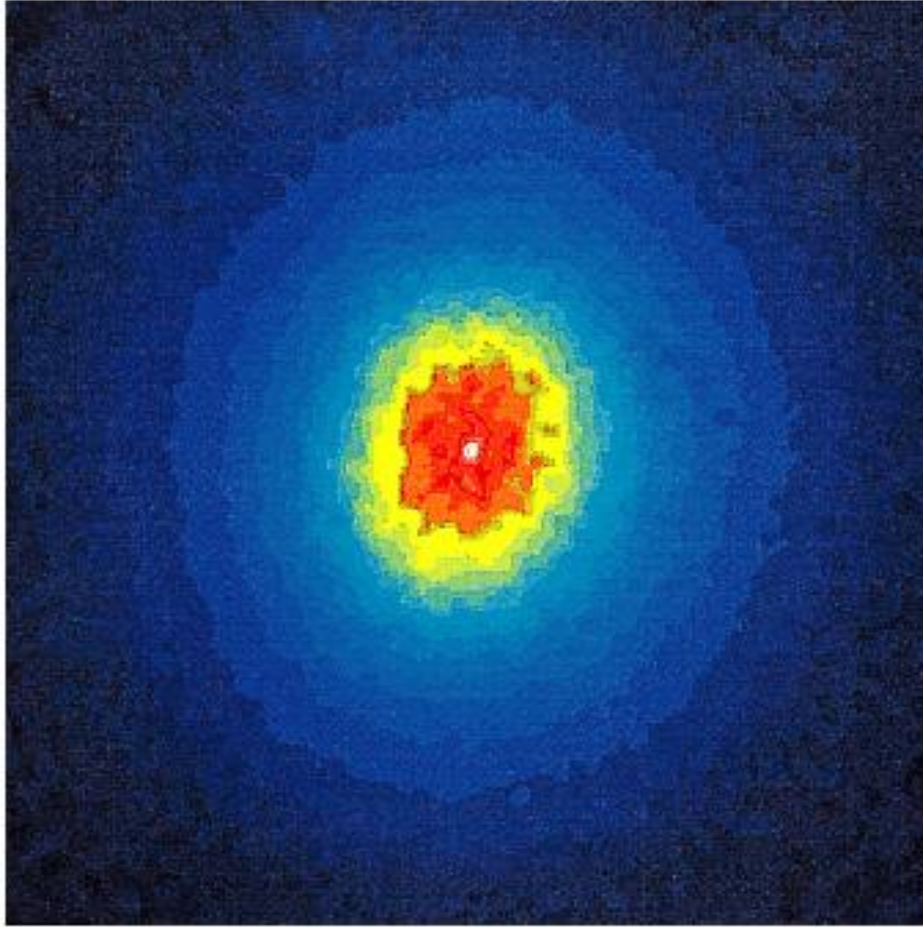

(a)

Copyright © Addison Wesley

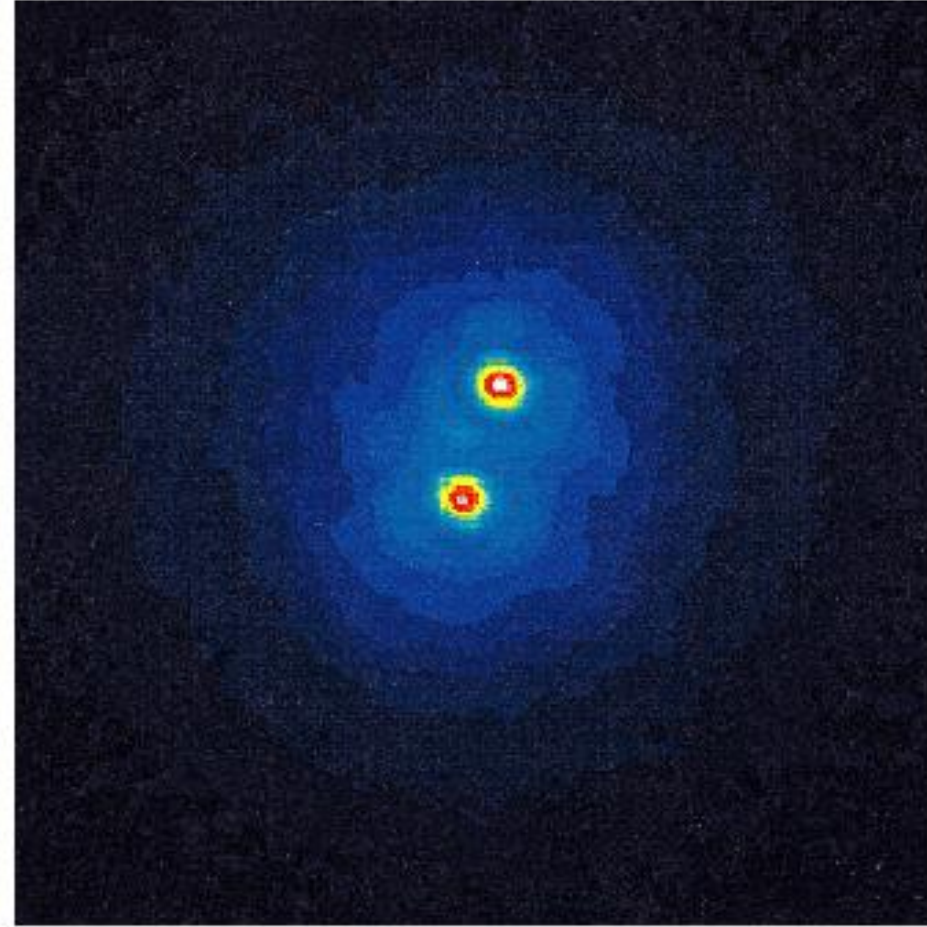

(b)

**Bir çift yıldızın Yer-konuşlu gözlemi**

**Aynı cismin “adaptive optics” sistem kullanarak gözlemi**

# ALTAIR

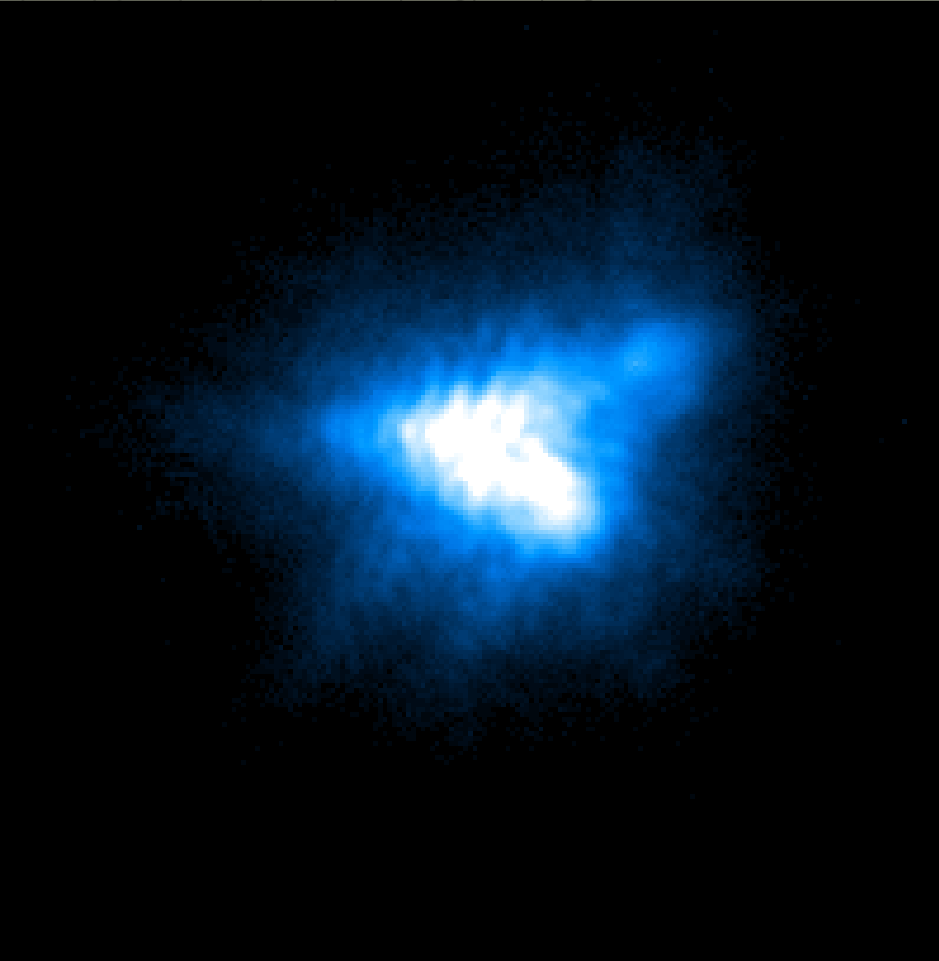

*Adaptive Optics yok*

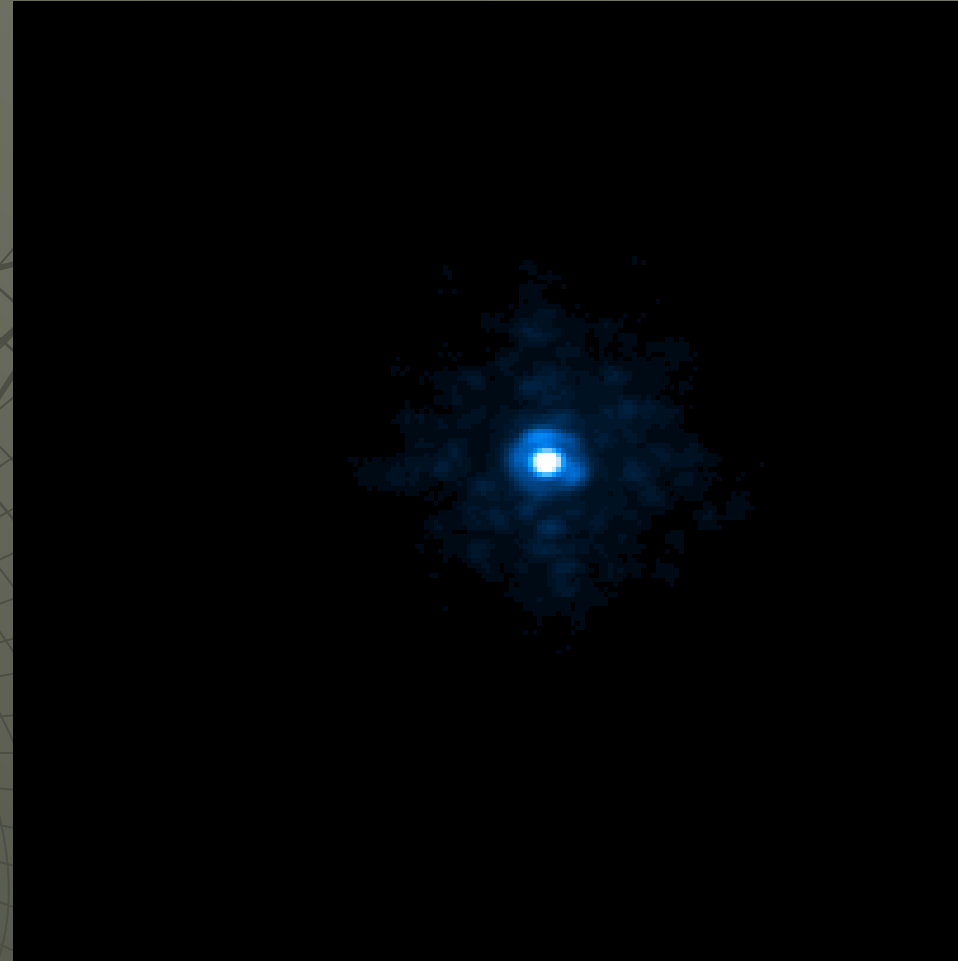

*Adaptive Optics ile*

# *Beta Delphinus'un Görüntüsü*

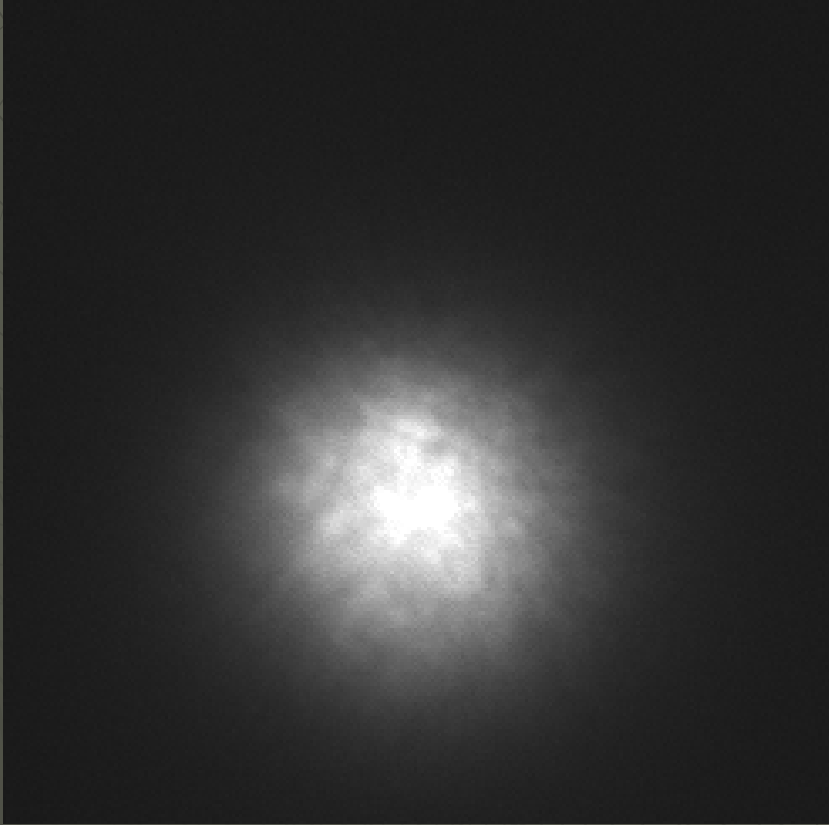

*Adaptive Optics yok*

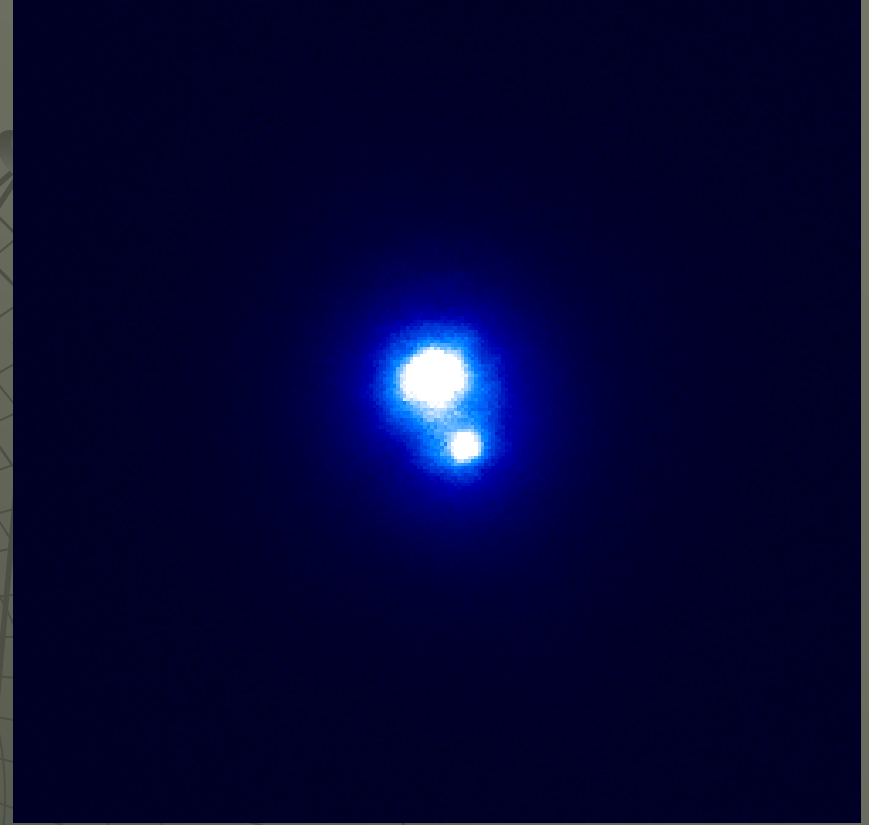

*Adaptive Optics ile*





# DÜNYANIN EN BÜYÜK TELESKOPLARI

<http://nineplanets.org/bigeyes.html>



Dünyanın en büyük gözlemevleri  
Mauna Kea, Hawaii, 4200 m.





# Keck I ve II Teleskopları



Optik teleskoplar  
10-m ayna (36 parça)  
Mauna Kea, Hawaii - 4200 m.





Keck I ve II Teleskopları



KECK  
GÖZLEMEVİ

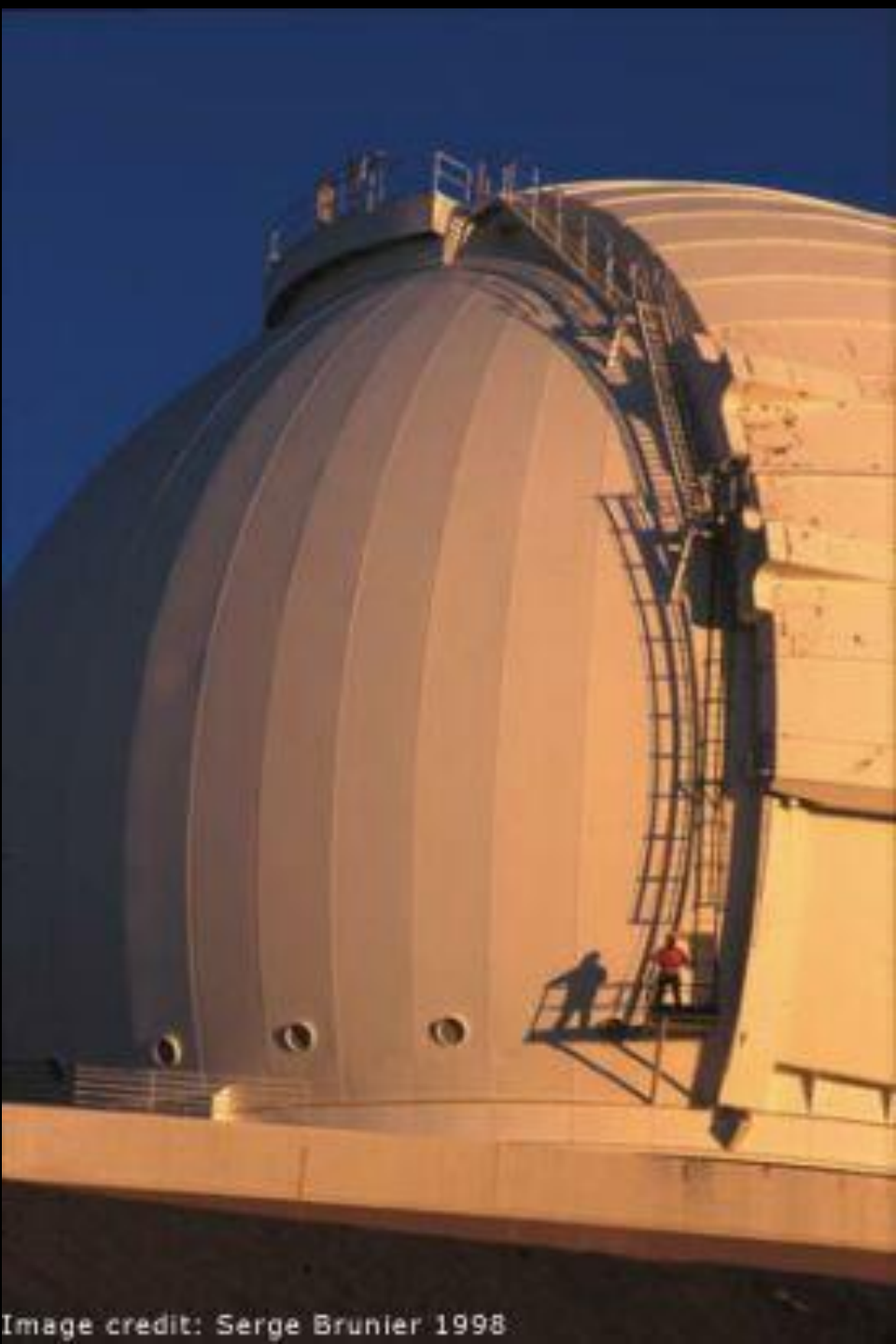

Image credit: Serge Brunier 1998

# Keck I ve II Teleskopları





# KECK Teleskobu Birincil Aynası ve Işık Yolu

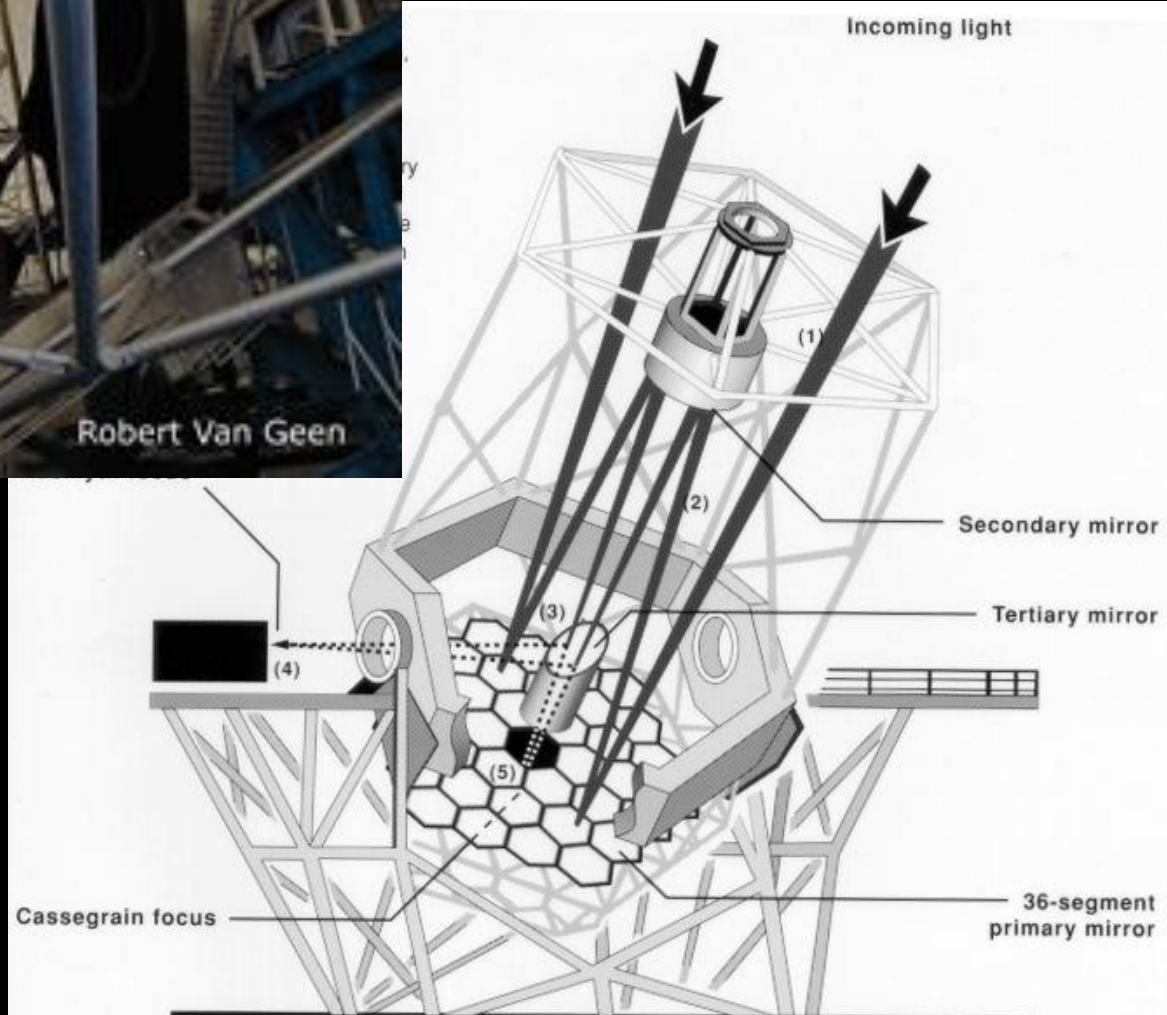





JAPON ULUSAL BÜYÜK TELESKOP PROJESİ

**SUBARU TELESKOBU**



SUBARU  
Ayna Çapı: 8.2 m

<http://www.naoj.org/>

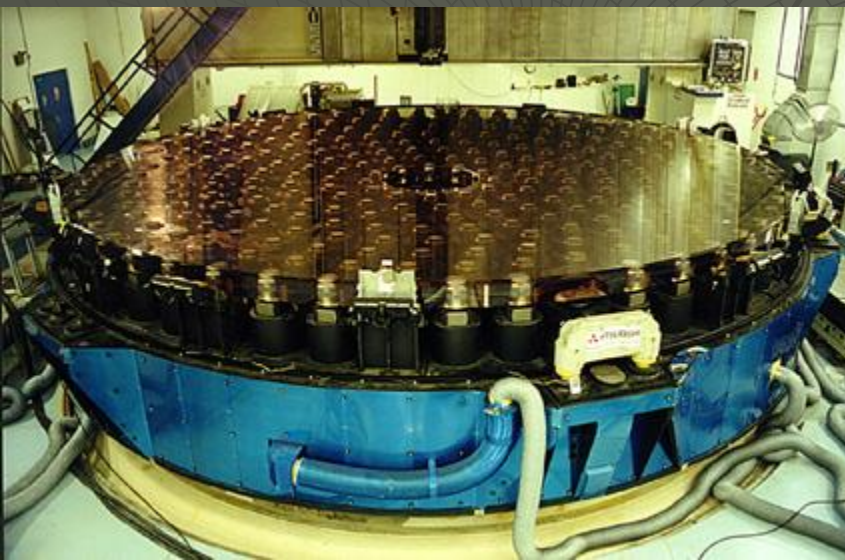

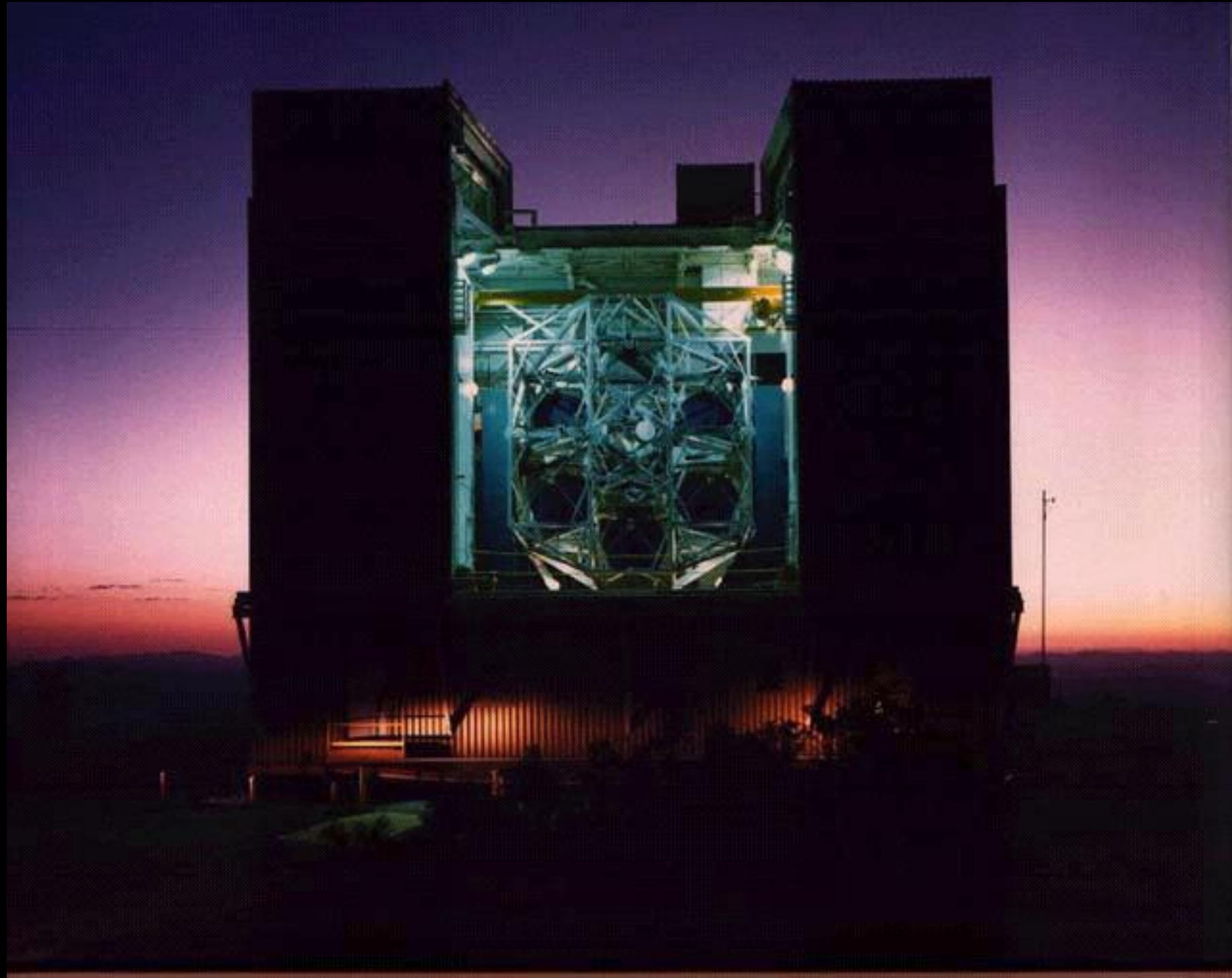



# GEMINI TELESKOBU, apı: 8.1 m



<http://www.gemini.edu/>



KUZEY GEMİNİ  
TELESKOBU



GÜNEY GEMİNİ  
TELESKOBU





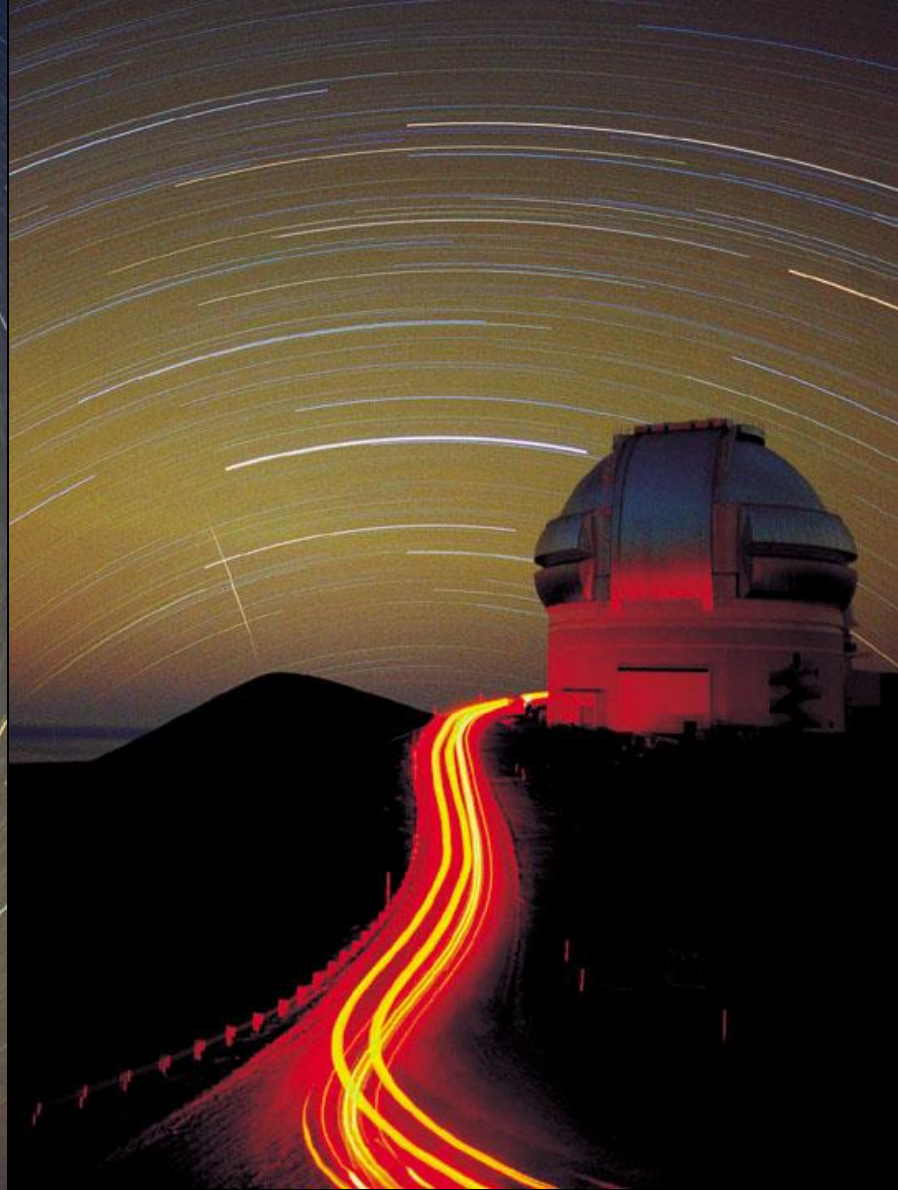

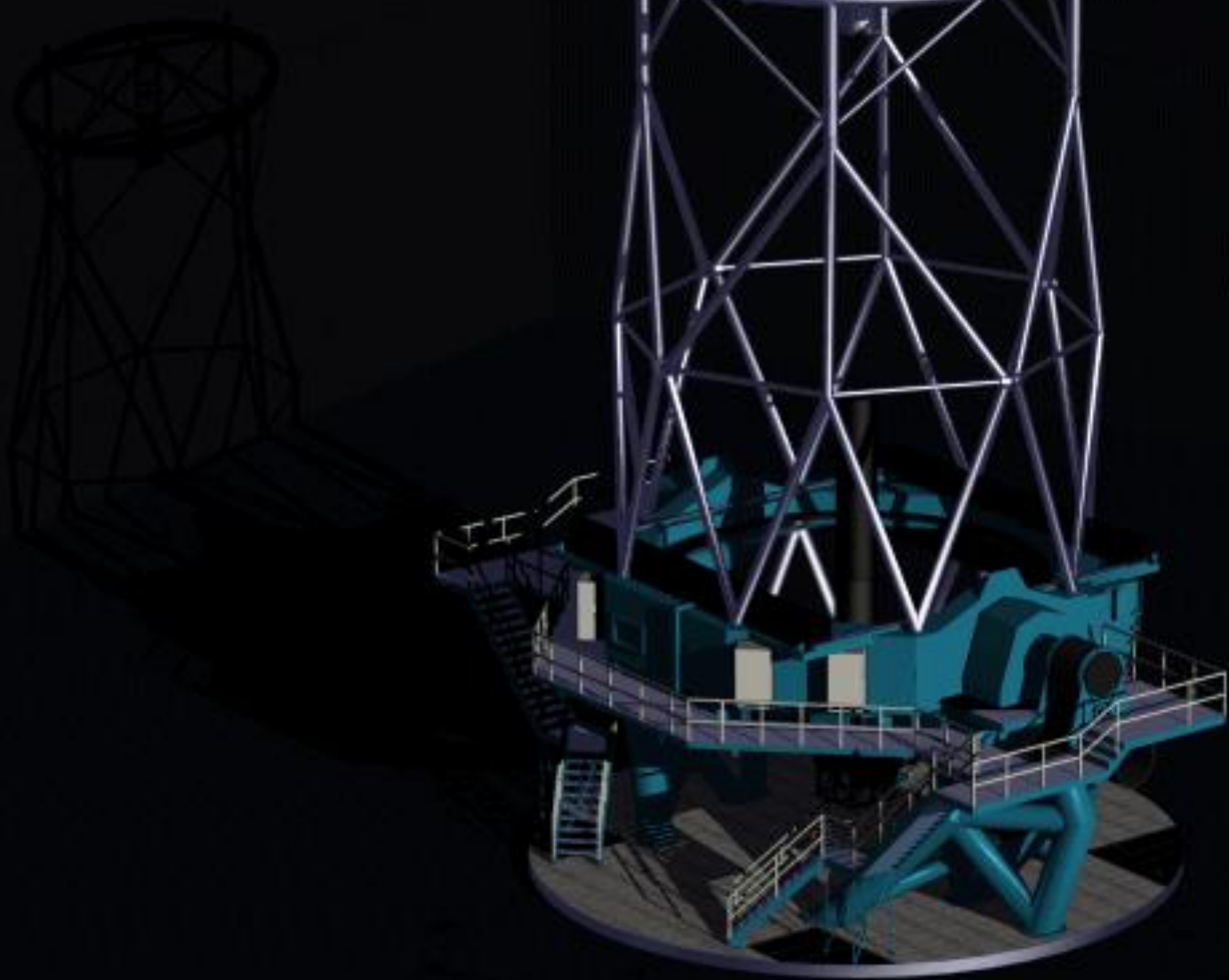



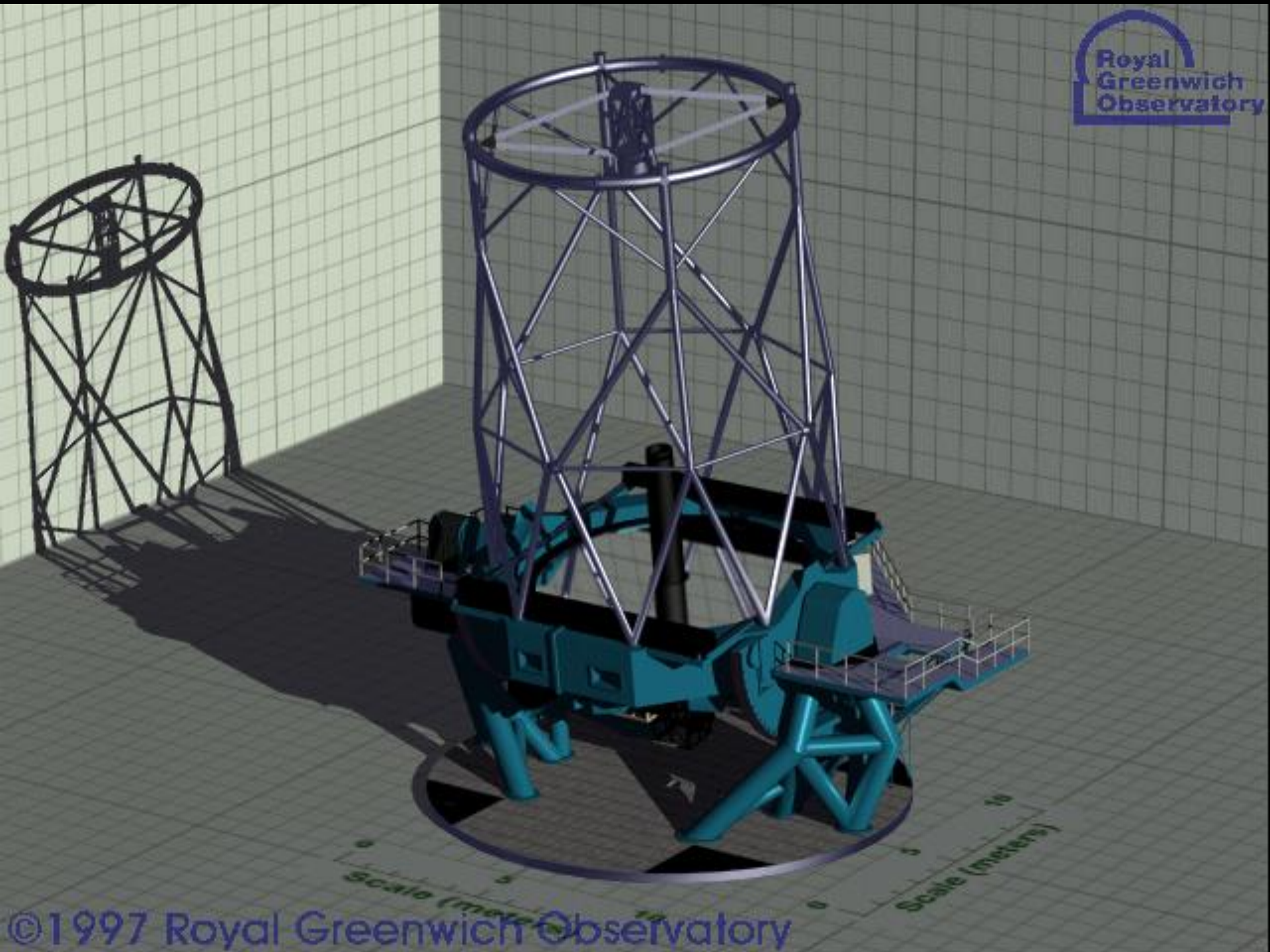







# GEMINI Teleskobu Aynası ve Kurgusu

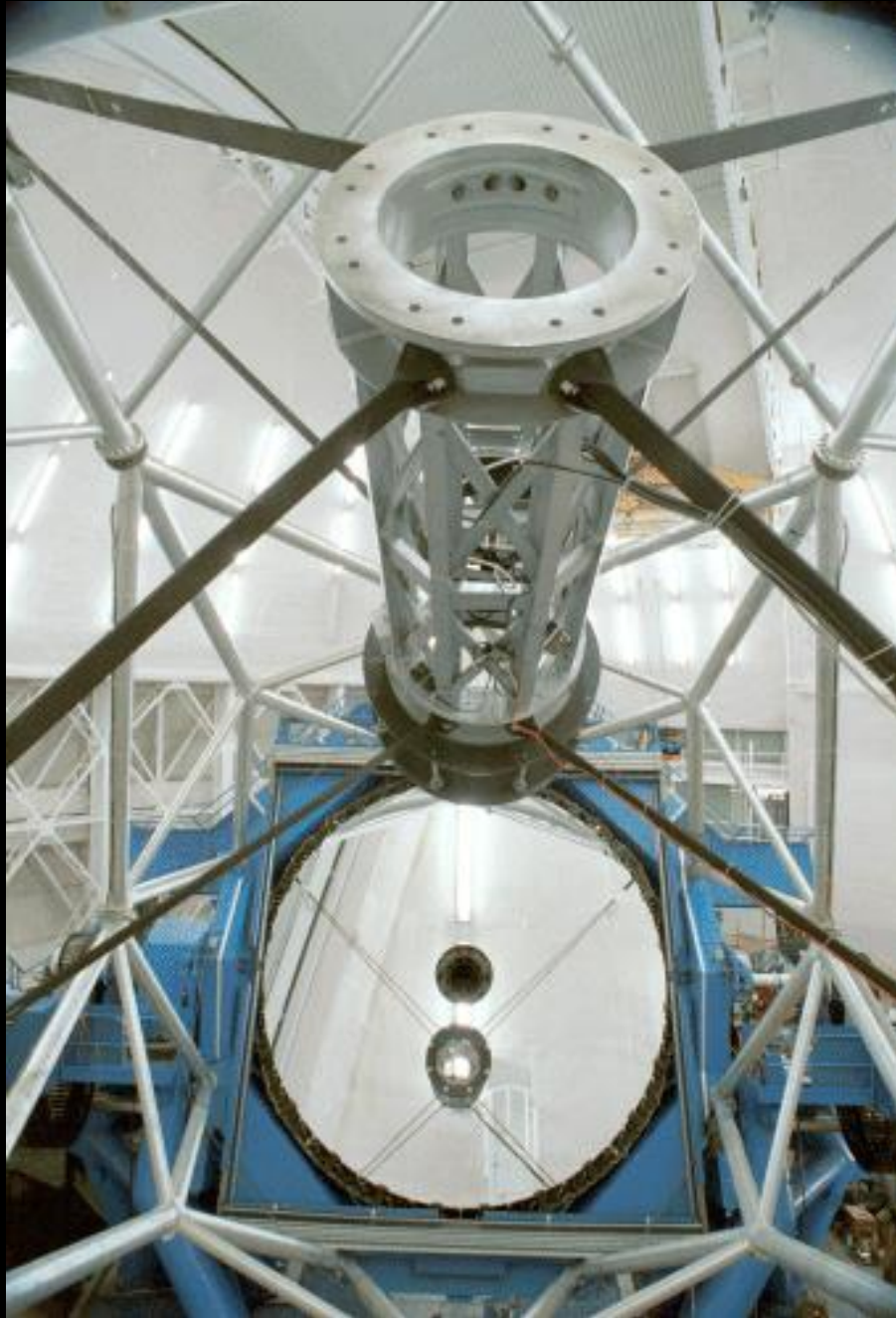

# Gemini Teleskobu Aynası





# European Southern Observatory (ESO) La Silla, Şili



Paranal Gözlemevi



Dünyanın en büyük optik teleskobu



# ESO; Very Large Telescope





# ESO VLT

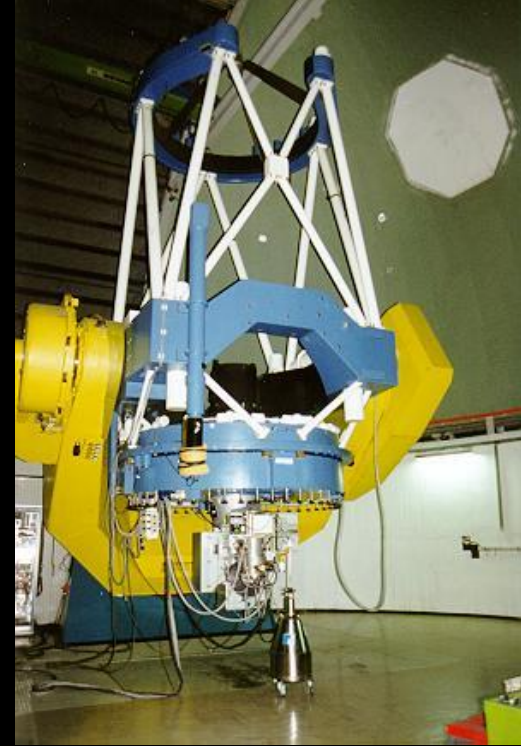
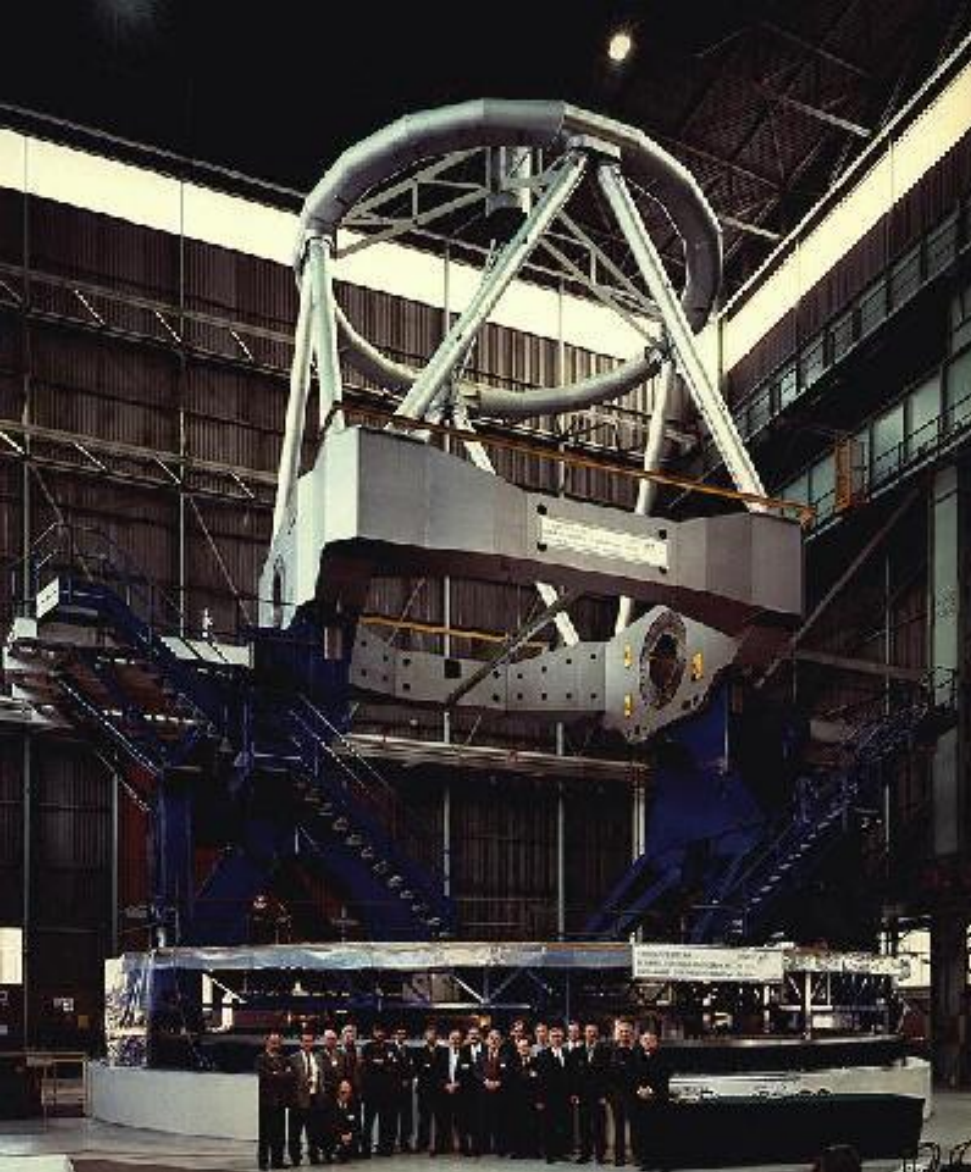



# Optical-Infrared Coordination Network for Astronomy (OPTICON)

## OPTICON Trans-national Access Programme





The HET at Mount Fowlkes

**HET**

# **HOBBY-EBERLY TELESKOBU**





•McDonald Gözlemevi'nde bulunmaktadır.

•Deniz seviyesinden 2000 m yükseklikte kurulmuştur.

•Çap: 9.2 m

# Radyo Teleskoplar

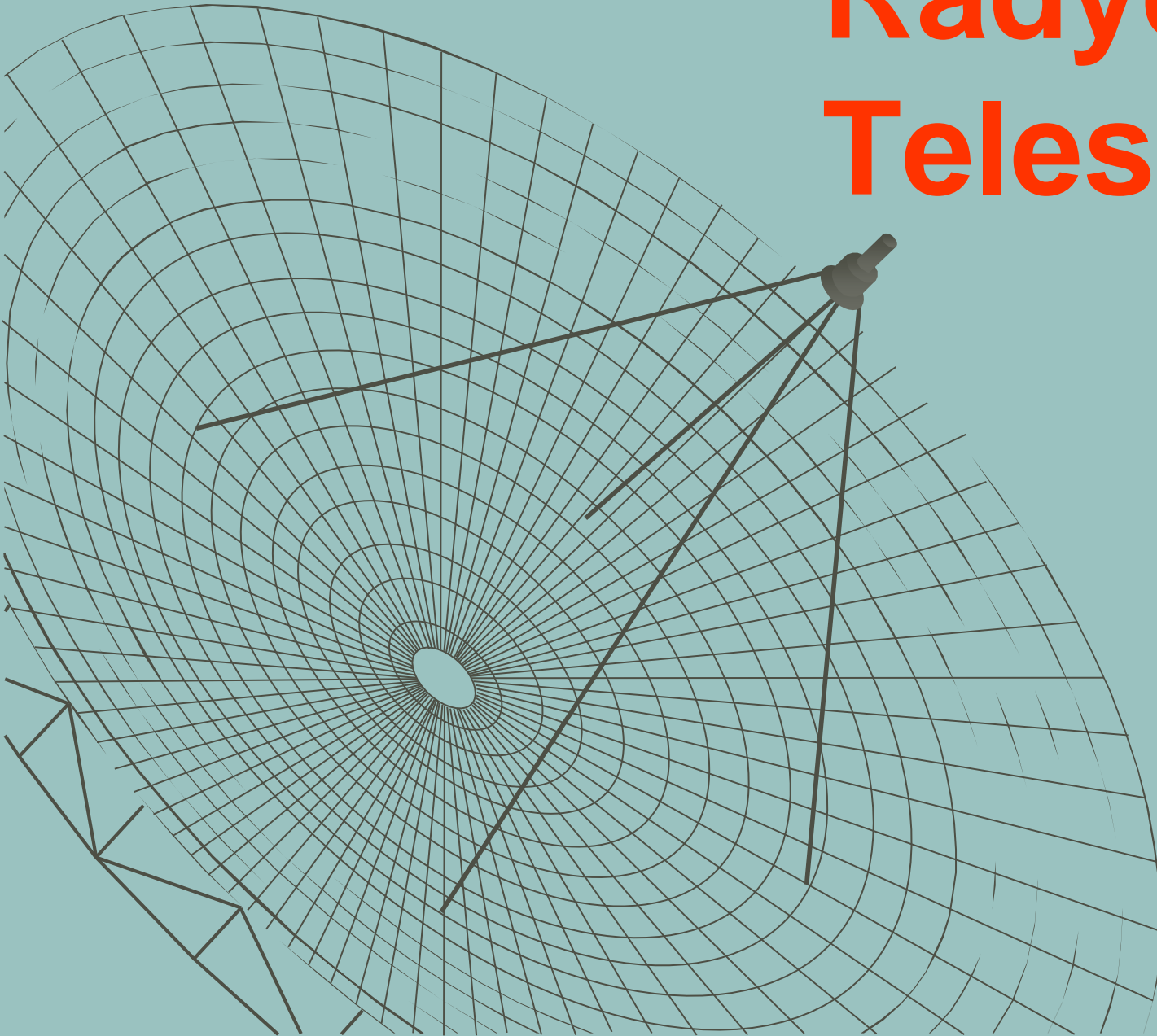

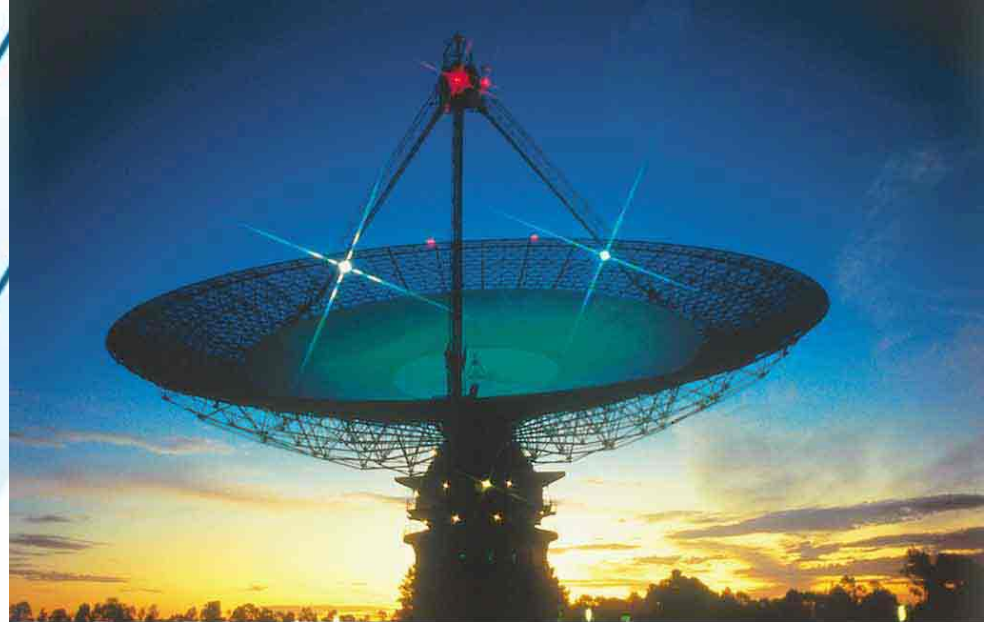
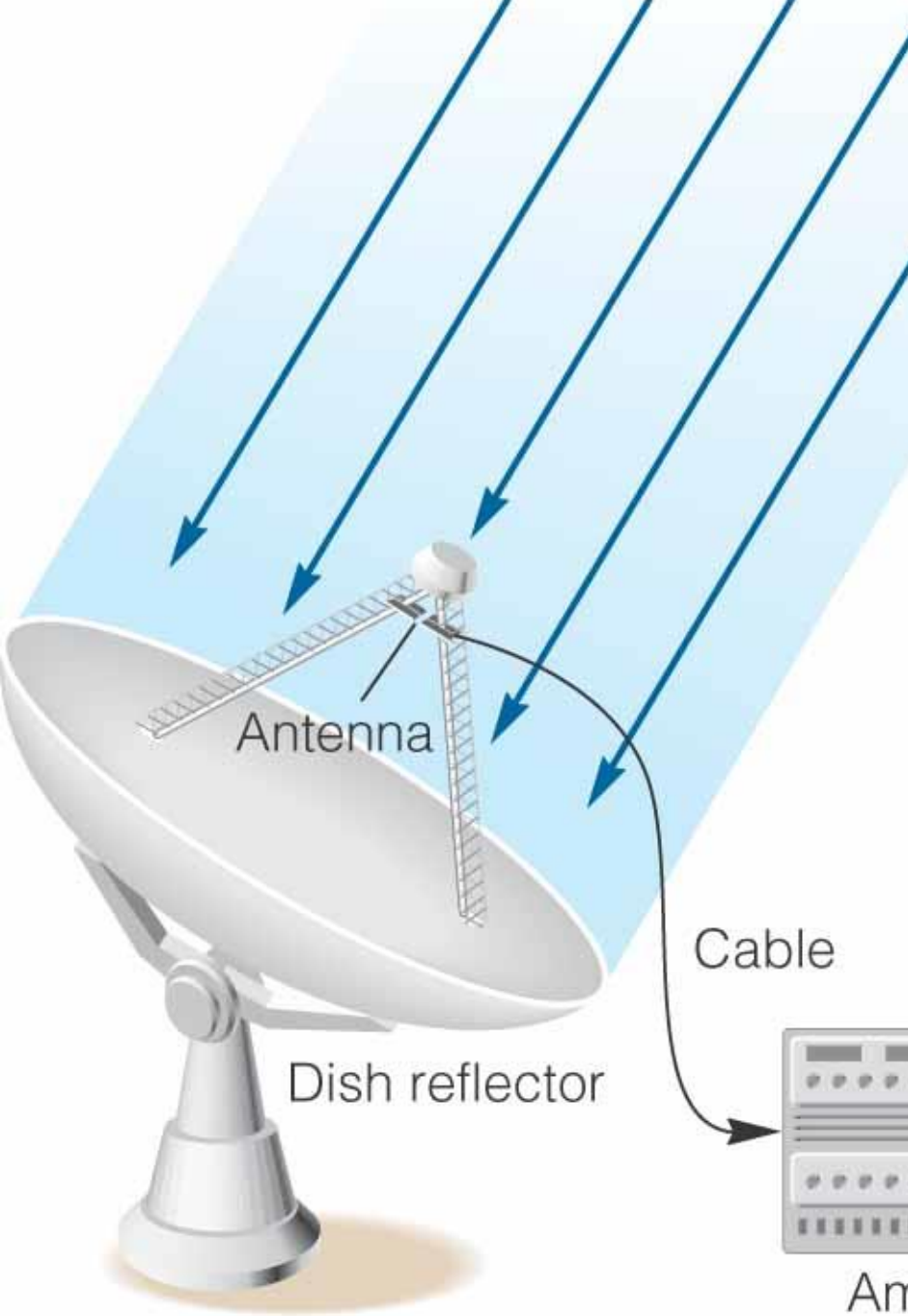

© 2004 Thomson - Brooks Cole



# Arecibo Radyo Teleskop (Puerto Rico)

Çapı: 305 m.





# Dünyanın en büyük radyo teleskobu ..ÇİN.. çapı 500 metre

The Five-hundred-meter Aperture Spherical radio Telescope (FAST)  
26 Eylül 2016





# Very Large Array (VLA)

- Y-şekilli 27 anten, her biri 25 m çapında
- Socorro, New Mexico







# Very Large Array (VLA)





# The Very Long Baseline Array (VLBA)

10 Radyo  
Teleskop



North Liberty, Iowa VLBA Telescope



# The Very Long Baseline Array

(VLBA)



# Uzay Teleskopları

# Hubble Uzay Teleskobu



Çap: 2.4 m

Uzaydaki İlk Büyük Optik Teleskop  
1990





Hubble Uzay Teleskobu: "600 km yukarıda"



# Hubble Uzay Teleskobu

Tamirat: 1994

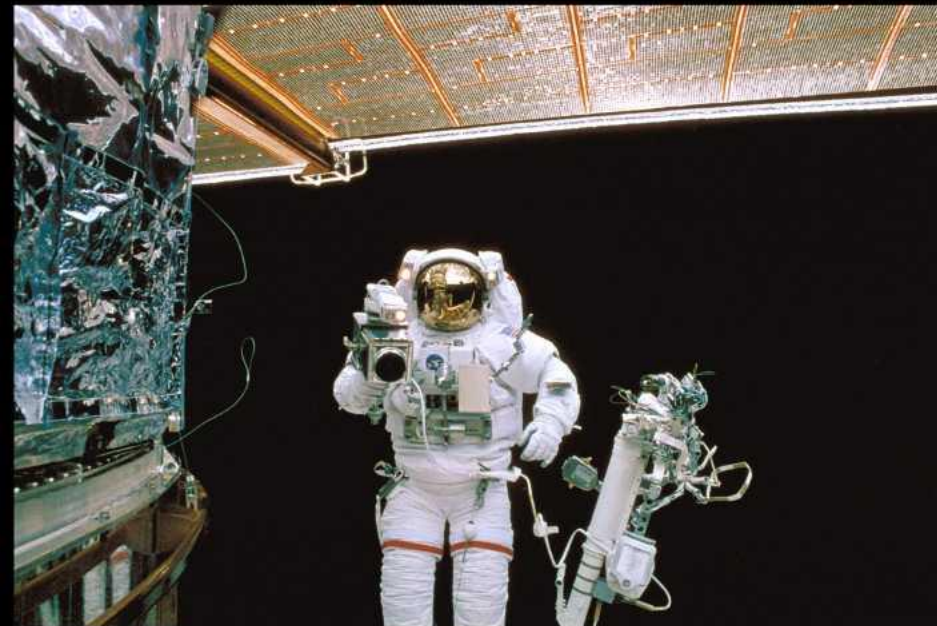

# Hubble ile haberleşme ve veri alış yolu

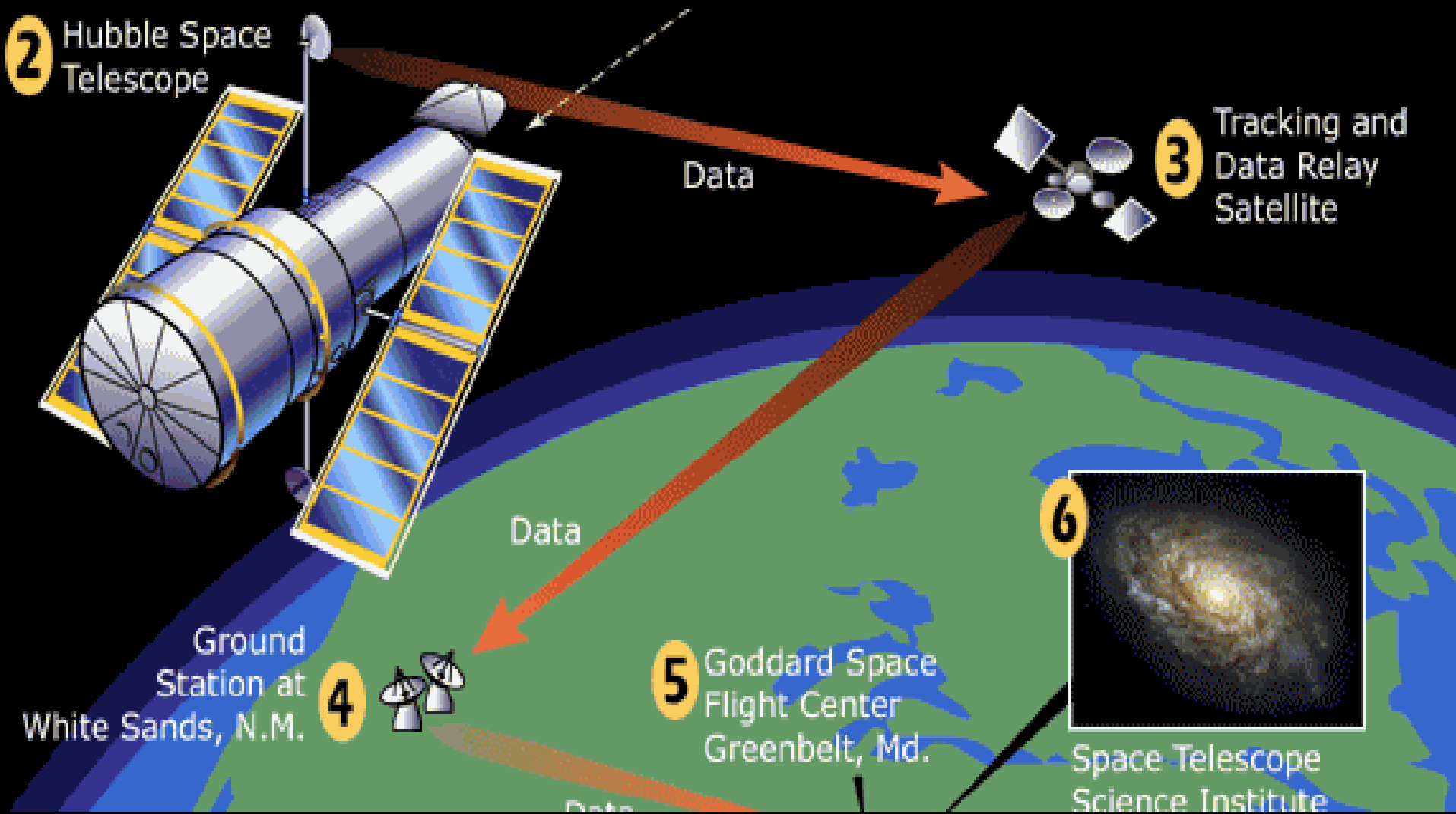



Infrared image

IRAS

# Kızılöte Teleskobu (IRAS)

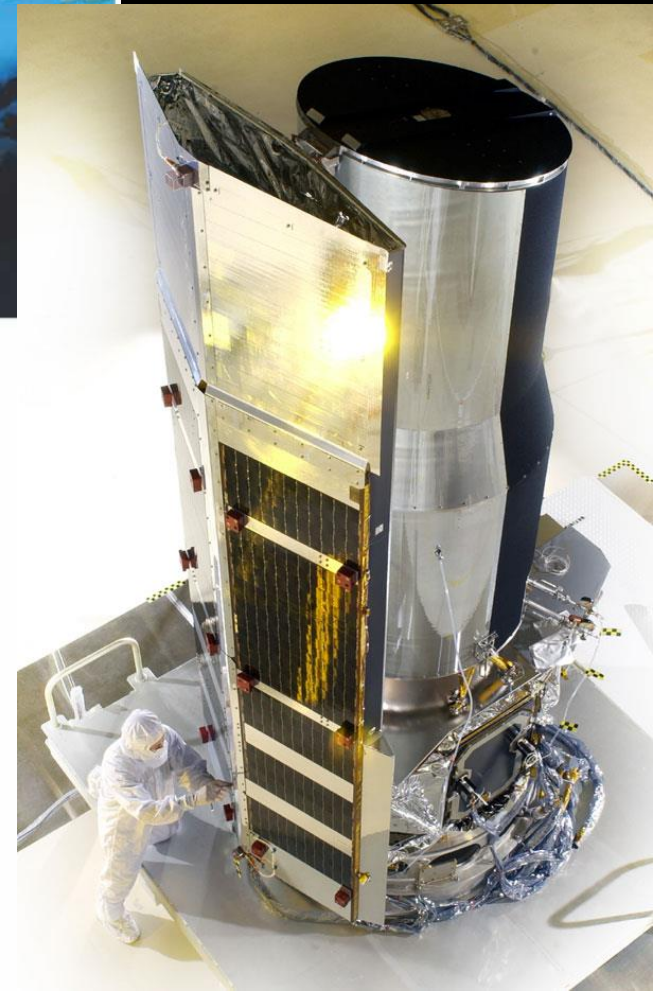
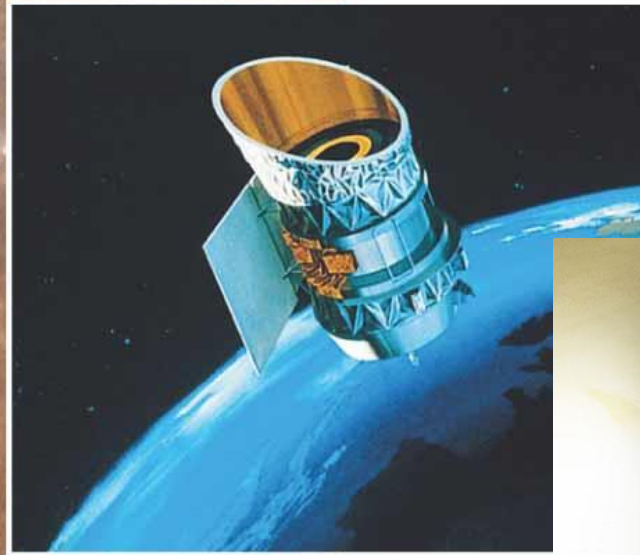

Stars

Interstellar dust warmed by starlight



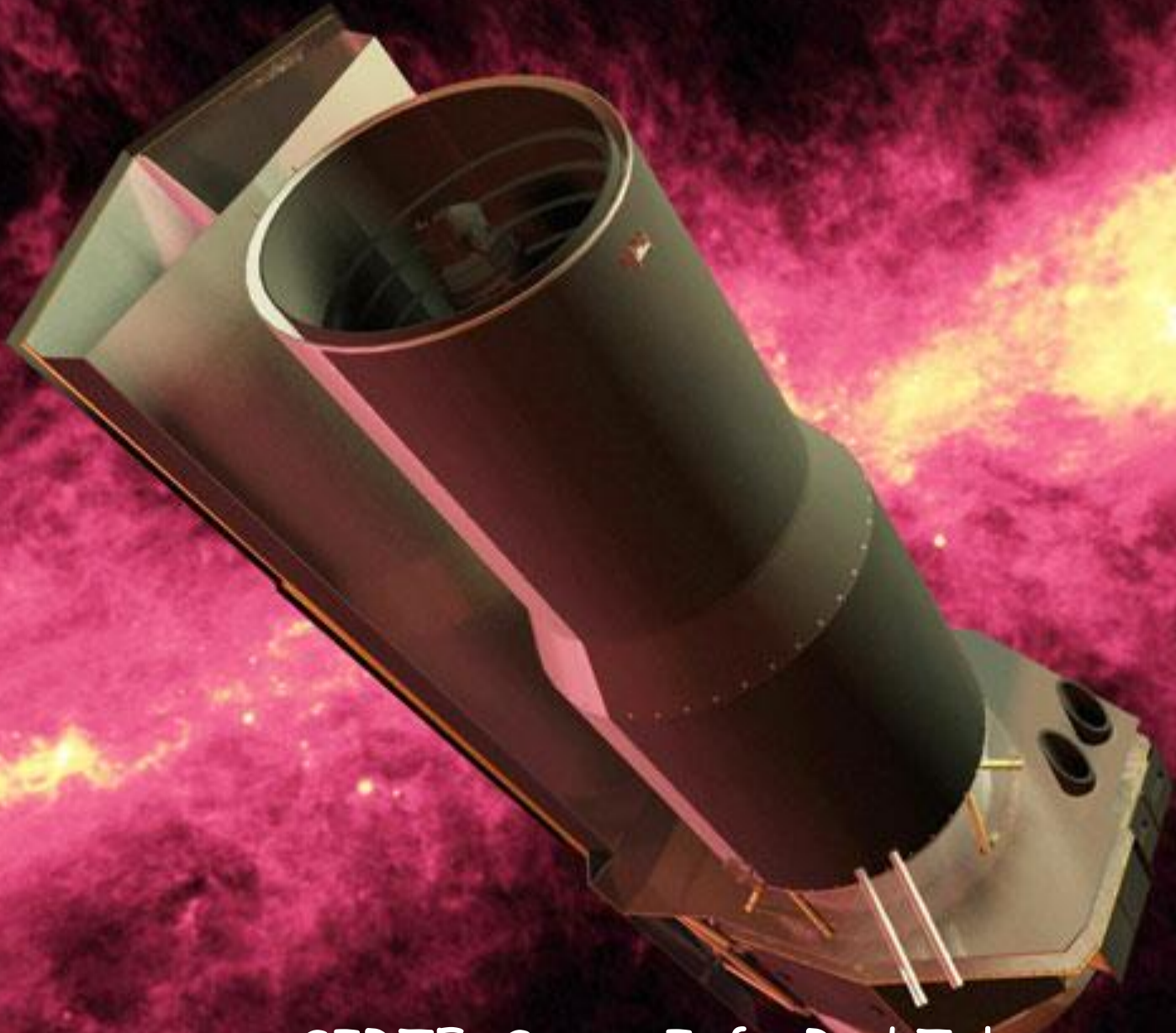

SIRTF: Space InfraRed Telescope Facility  
(Yer Yörüngesinde: bir "Kızılöte Hubble")

# Uzak Moröte Teleskobu (EUVE)

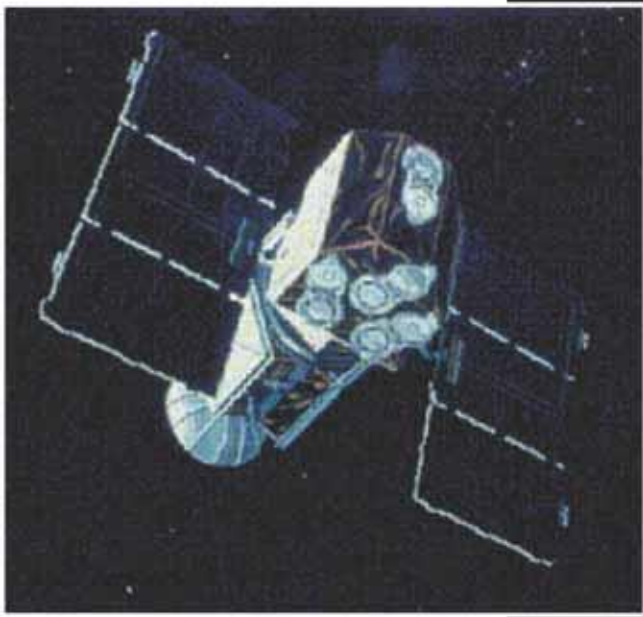

EUVE

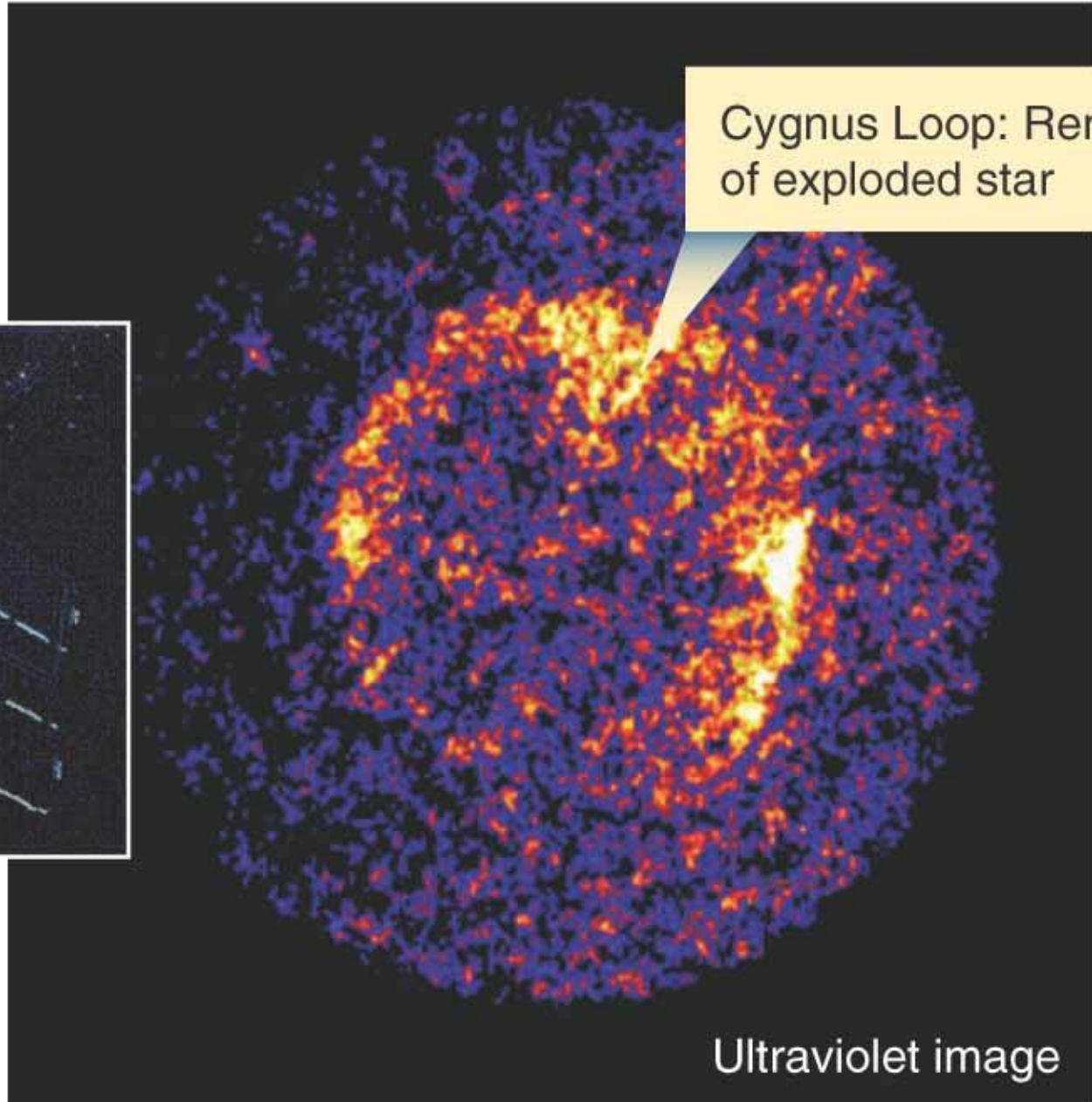

Cygnus Loop: Remains of exploded star

Ultraviolet image



# Chandra X-Işın Teleskobu



# Compton Gamma Işın Teleskobu

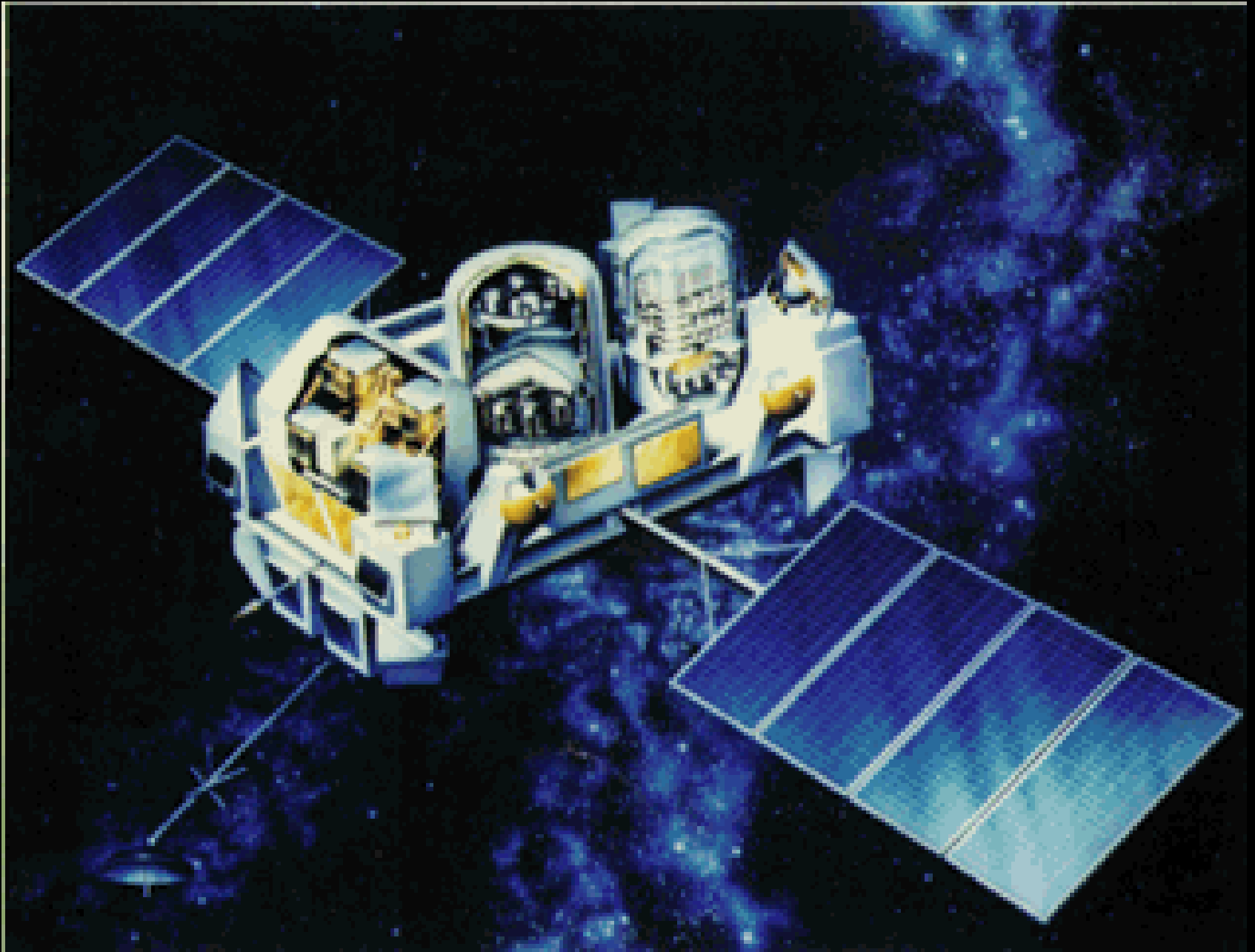

# Solar Heliospheric Observatory Güneş Teleskobu (SOHO)

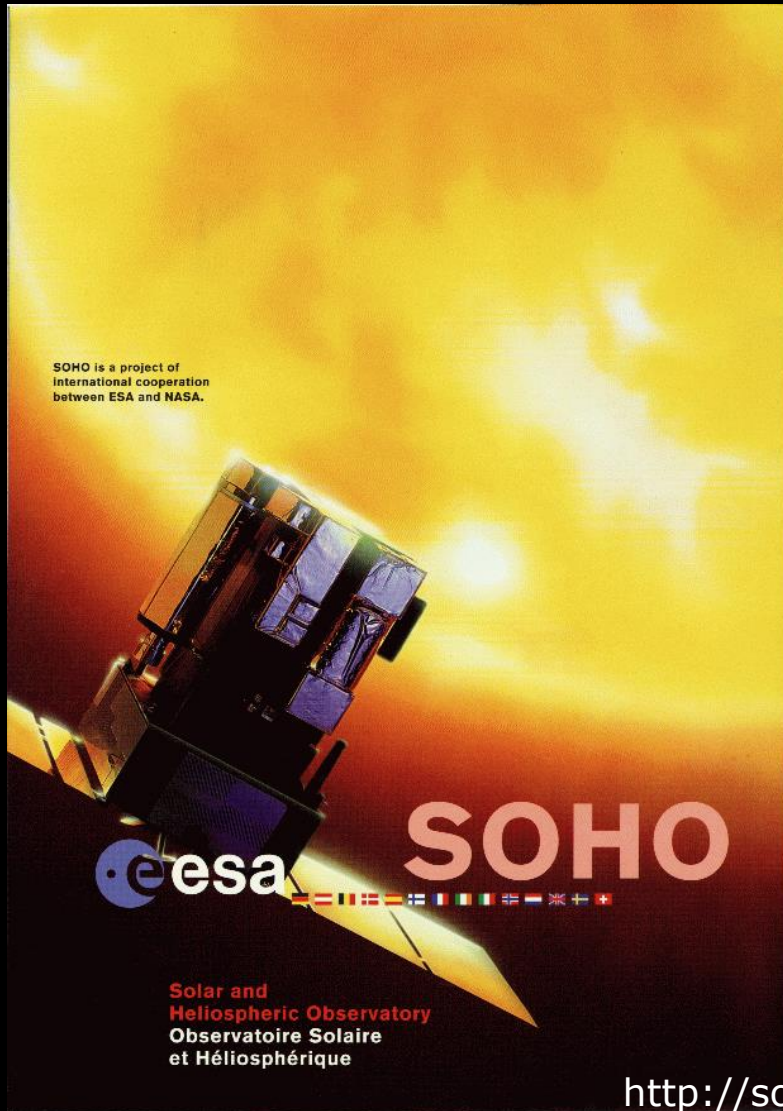



**Low-gain antennae**

**SOHO**

1.5 milyon km yukarıda

**High-gain antenna**

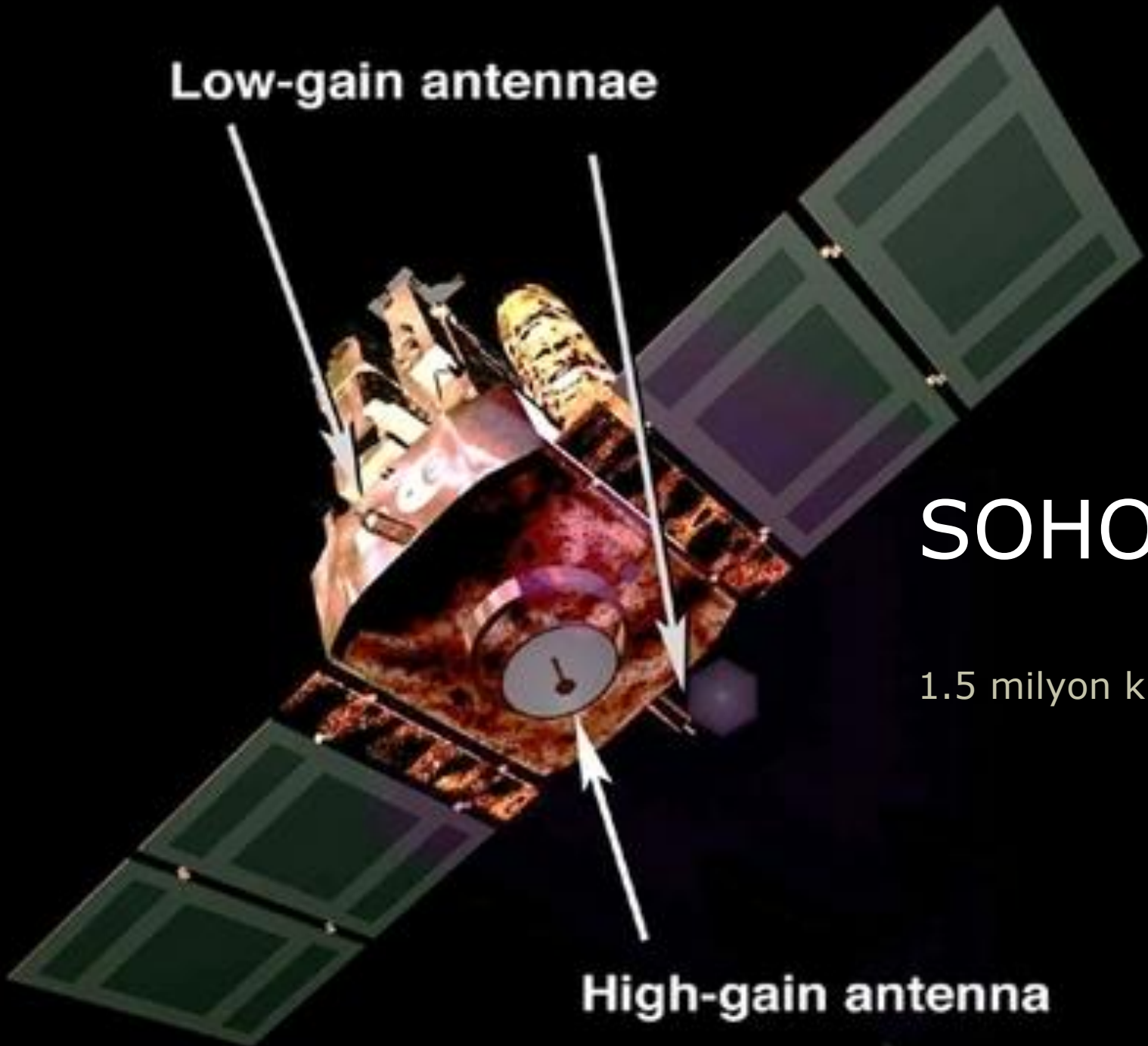

15 Mayıs 2001

28 Mart 2000

2 Şubat 2001

18 Ocak 2000

Güneş üzerindeki  
patlamalar  
SOHO

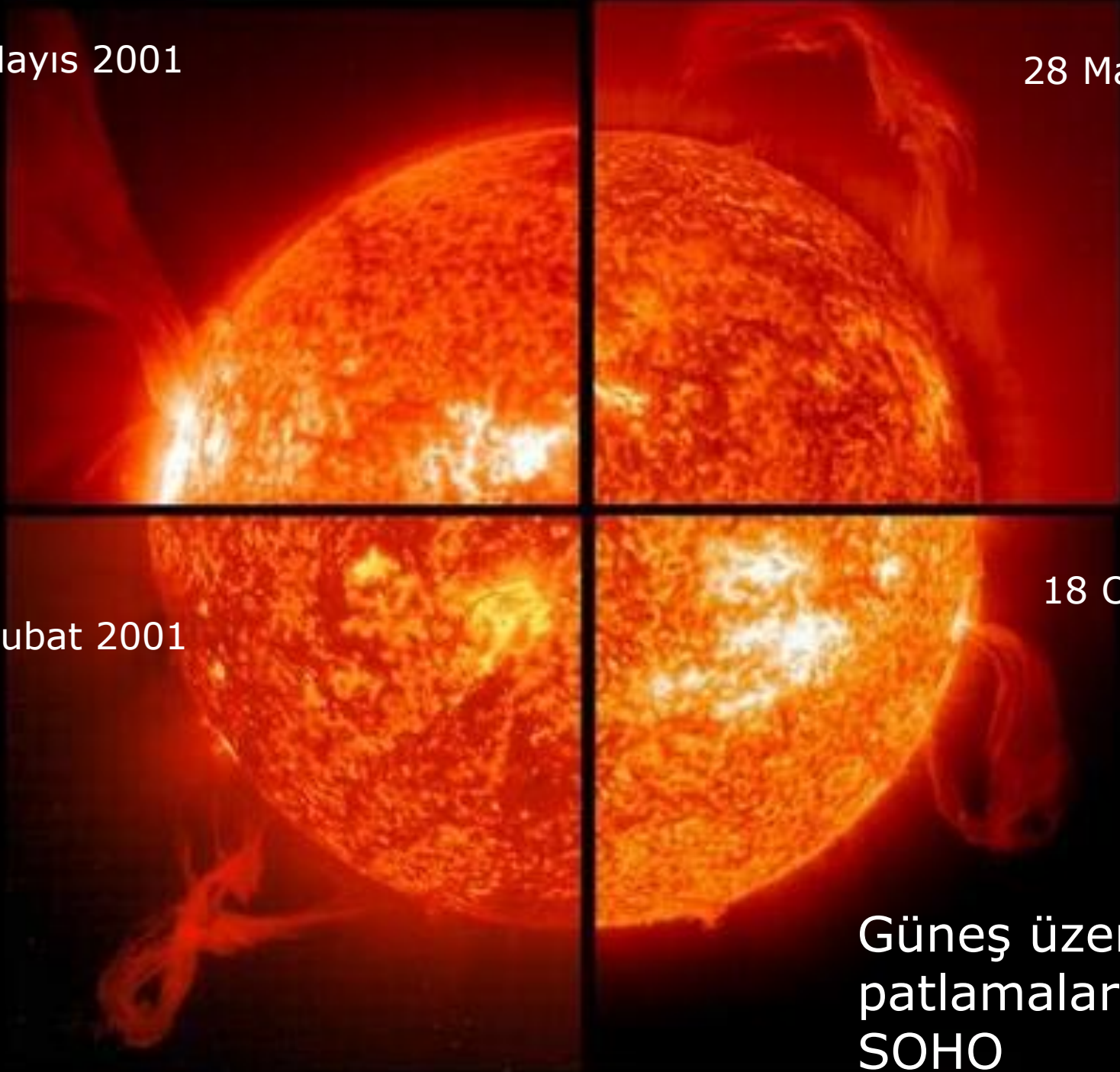

**GELECEKTE !**



# OWL *Overwhelmingly Large* 100 m apında optik ve kızılöte teleskobu



Aık havada bulunacak, gndz zerine kubbe kaydırılacak





OWL

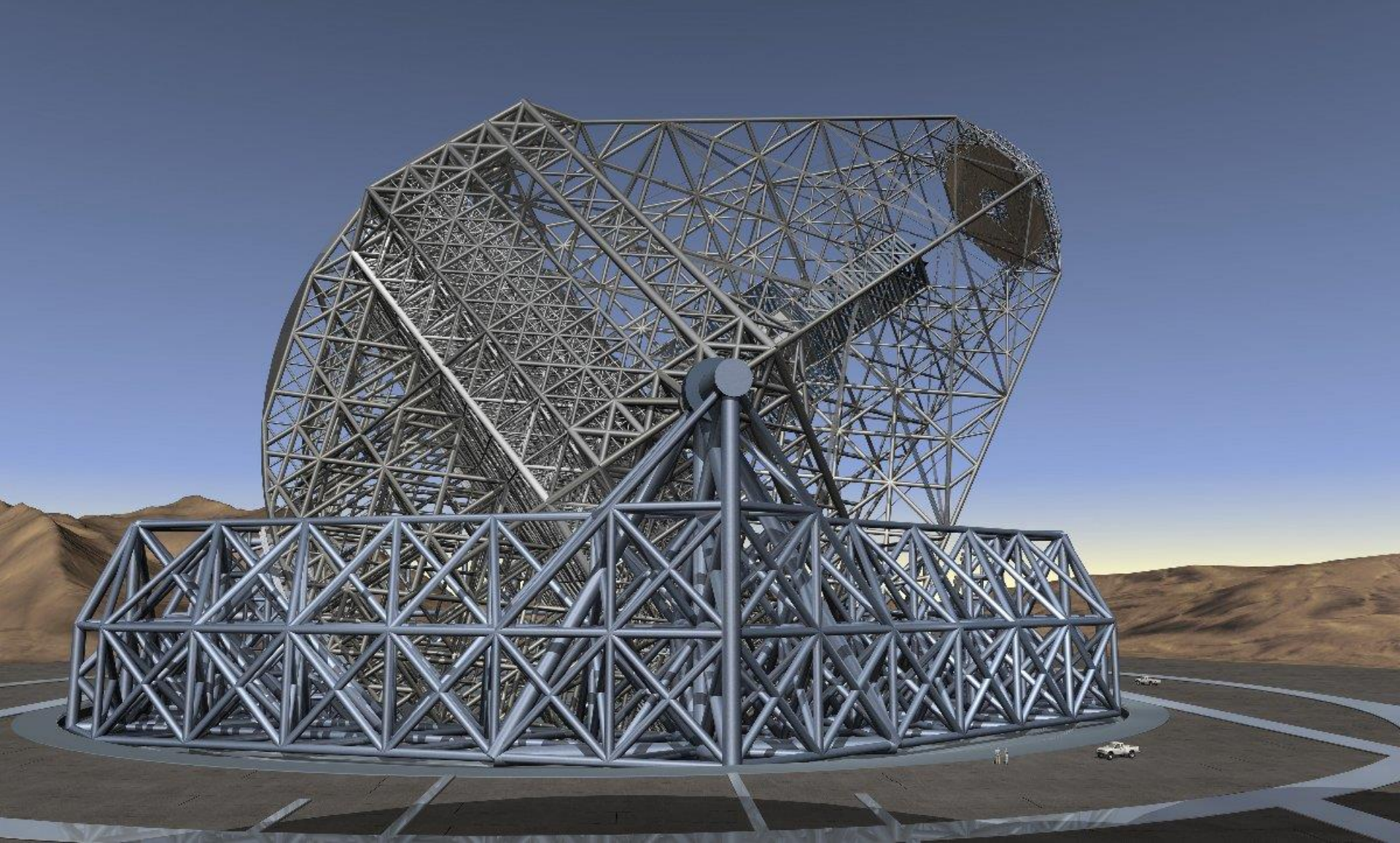



# OWL ile Artan Görüntü Kalitesi

[http://www.eso.org/projects/owl/index\\_3.html](http://www.eso.org/projects/owl/index_3.html)

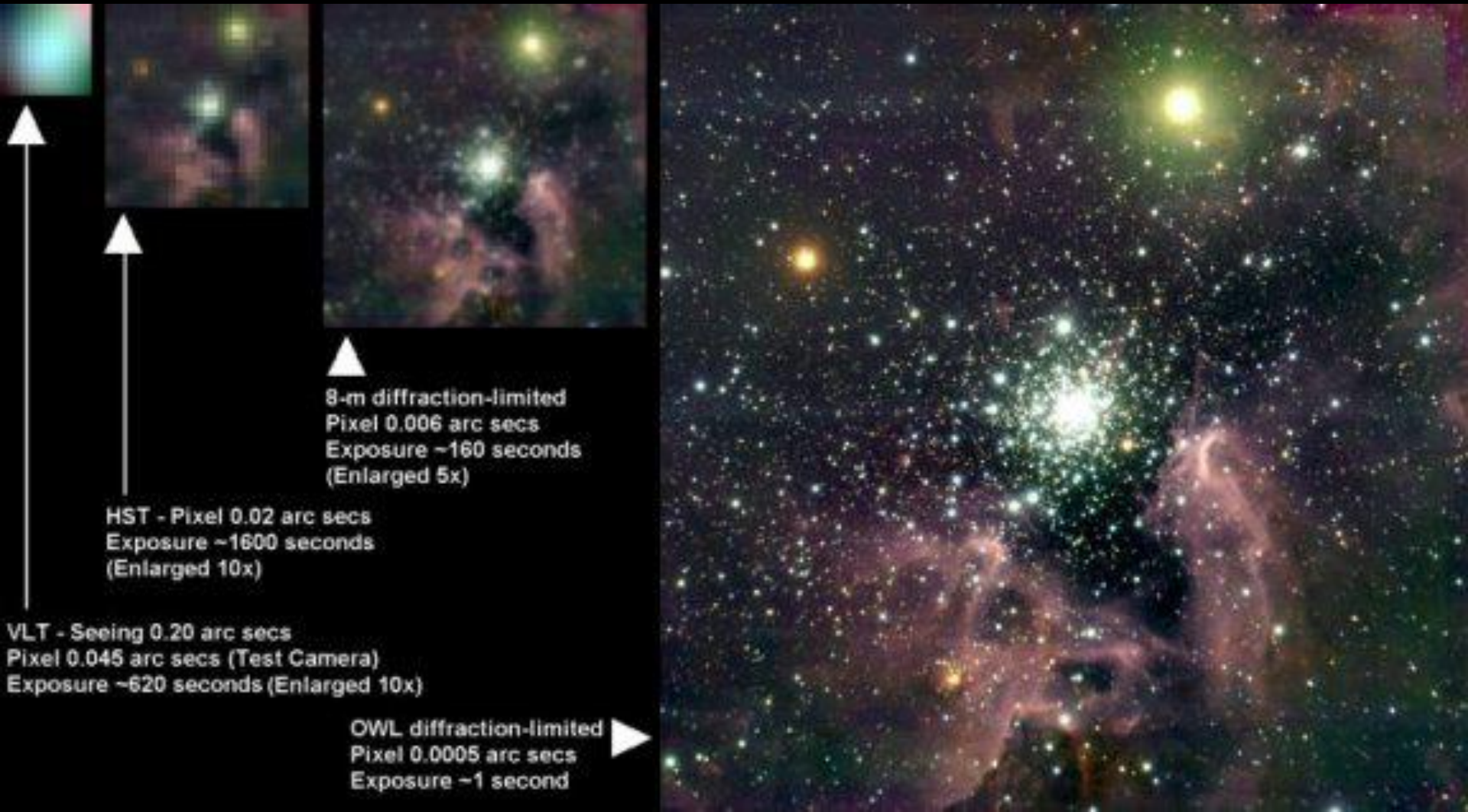



# EURO50

Finlandiya, İrlanda, İspanya, İsveç ve İngiltere

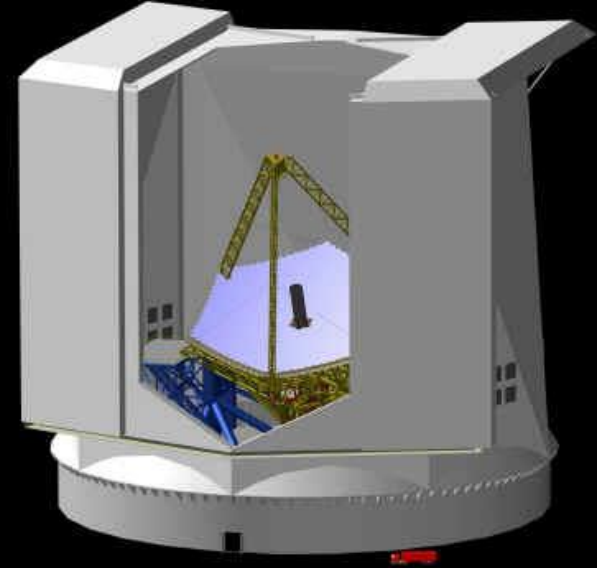

<http://www.astro.lu.se/~torben/euro50/>

Çapı: 50 m.

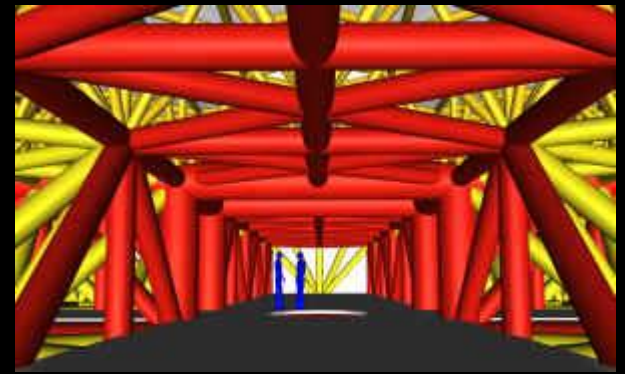
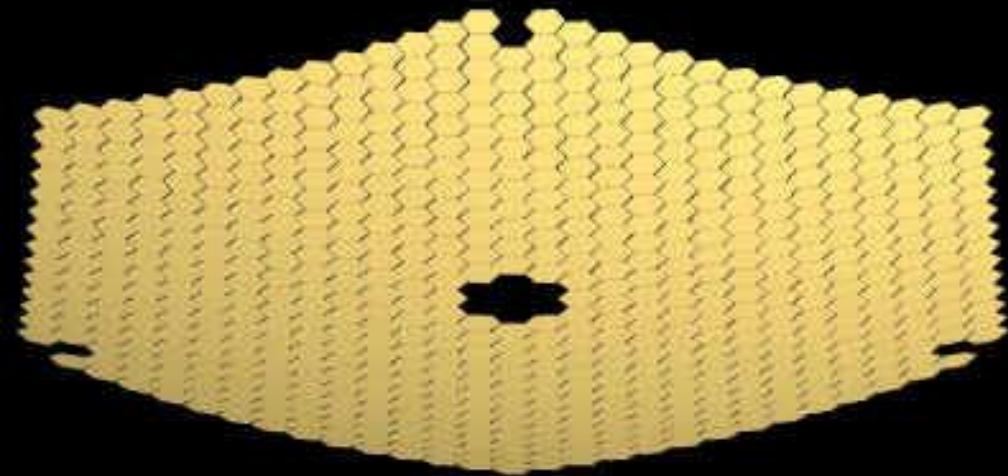

EURO50  
optik dizaynı

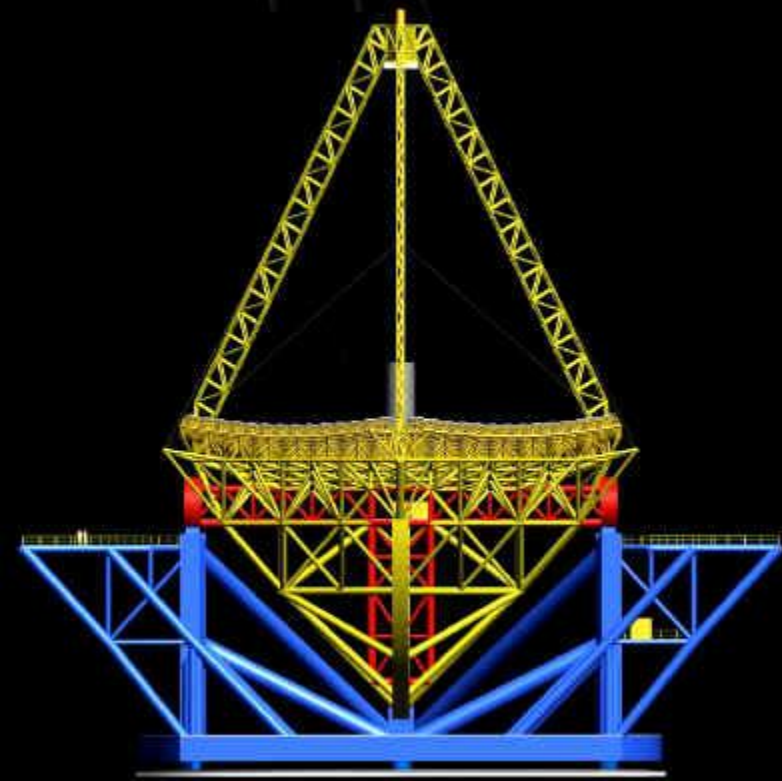

# EURO50 ve Boing 747

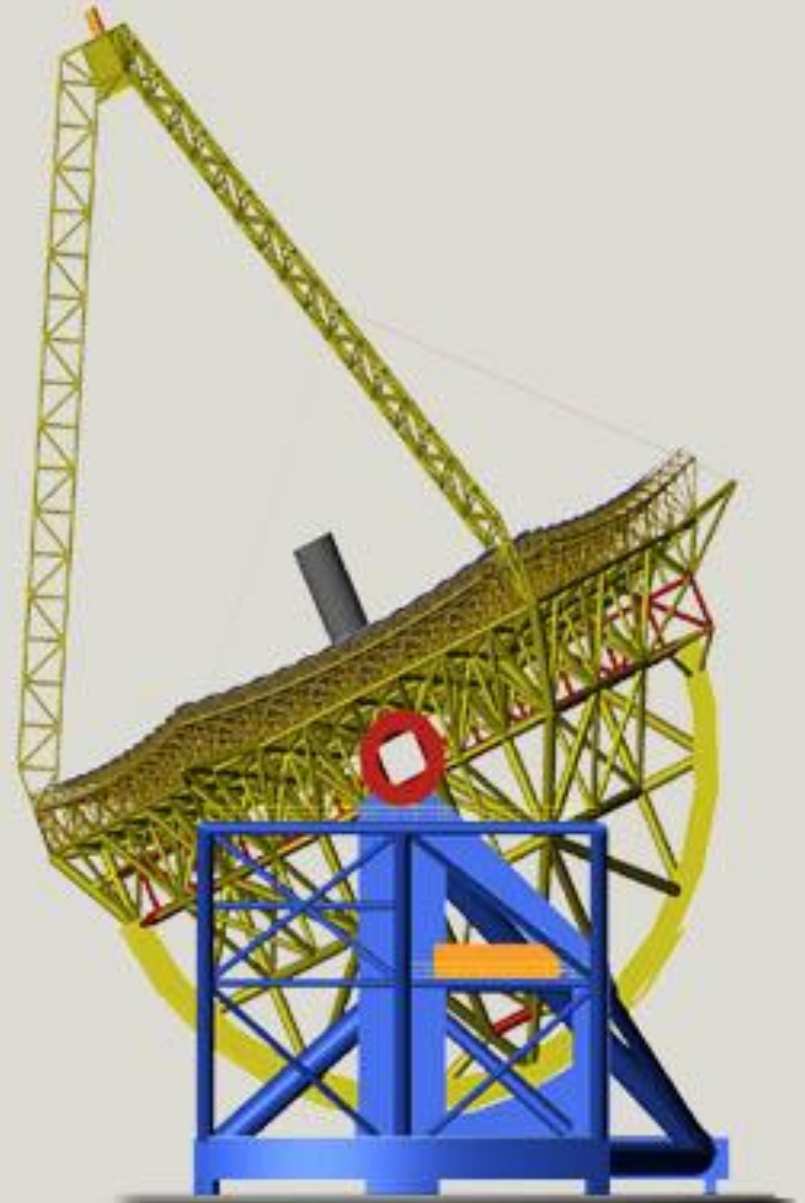



Bölüm Sonu...

